

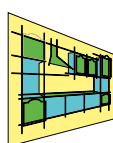

ФАСАД



**ЮГФАСАД**  
МЕБЕЛЬНЫЕ ФАСАДЫ

2024

**КАТАЛОГ ФАСАДОВ**



ТЕХНИЧЕСКАЯ ИНФОРМАЦИЯ.....	3
ОБКАТЫ.....	4
КАТЕГОРИЯ 1.....	5
КАТЕГОРИЯ 2.....	10
КАТЕГОРИЯ 3.....	13
КАТЕГОРИЯ 4.....	32
КАТЕГОРИЯ 5.....	42
КАТЕГОРИЯ 6.....	53
КАТЕГОРИЯ 3D.....	59
ВИТРИНЫ 1 КАТ.....	68
ВИТРИНЫ 3 КАТ.....	68
ВИТРИНЫ ФИГУРНЫЕ.....	69
РЕШЁТКИ.....	72
ДВЕРИ КУПЕ.....	74
ИНТЕГРИРОВАННЫЕ РУЧКИ.....	76
ДЕКОРАТИВНЫЕ ЭЛЕМЕНТЫ.....	77
КАРНИЗЫ.....	78
РАСПОЛОЖЕНИЕ КАРНИЗА, ПЬЕДЕСТАЛ.....	79
БАЛЮСТРАДЫ, КОЛОННЫ 2D.....	80
КОЛОННЫ 3D.....	81
ДУГИ, ДЕКОРЫ.....	83
ФРИЗЫ, ЦОКОЛИ.....	84
ПАТИНА.....	85
ЦВЕТА ПАТИНЫ.....	86
ФАСАДЫ С ПОКРЫТИЕМ «ТИСНЕНИЕ».....	87
ШТАПИКИ.....	88

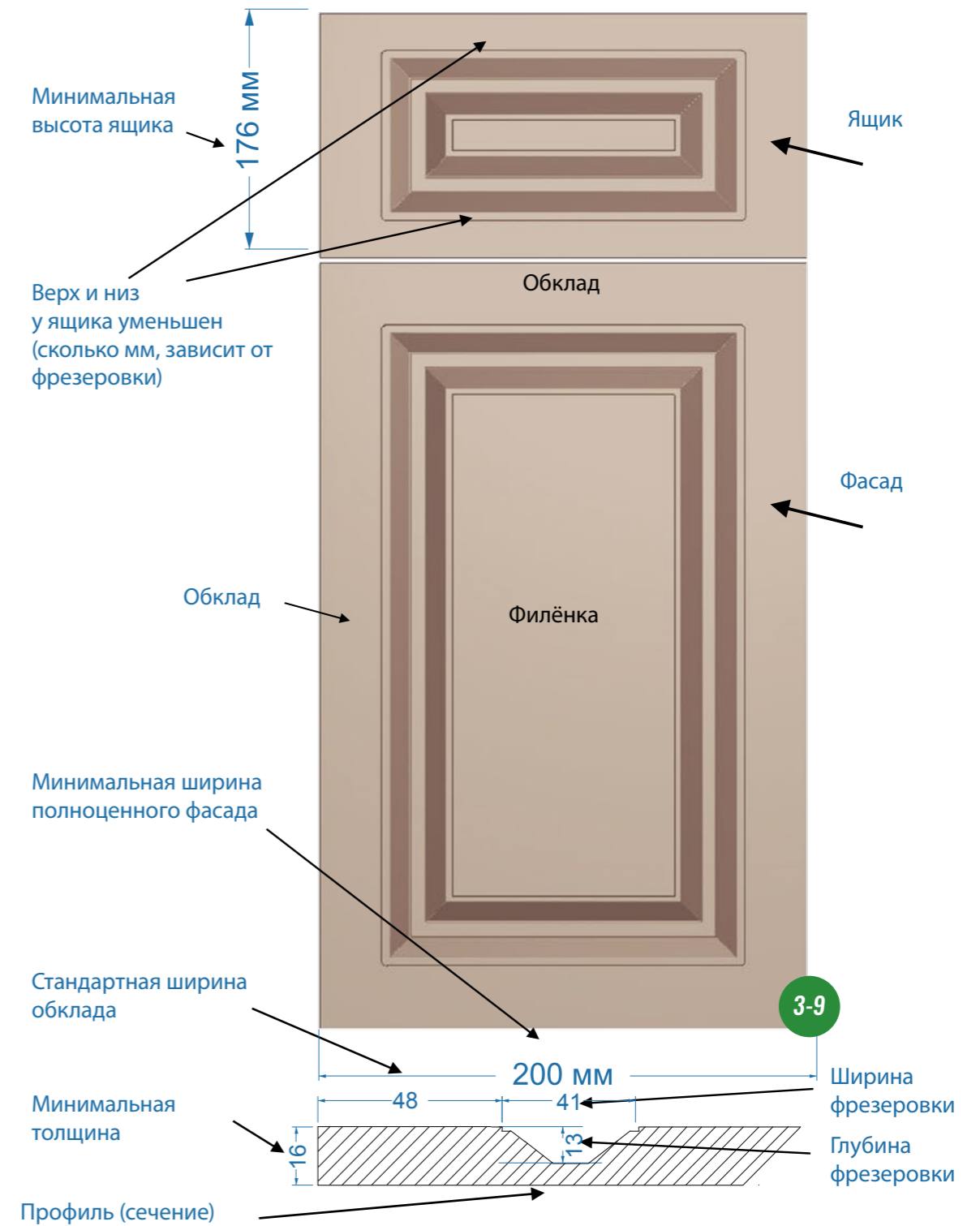

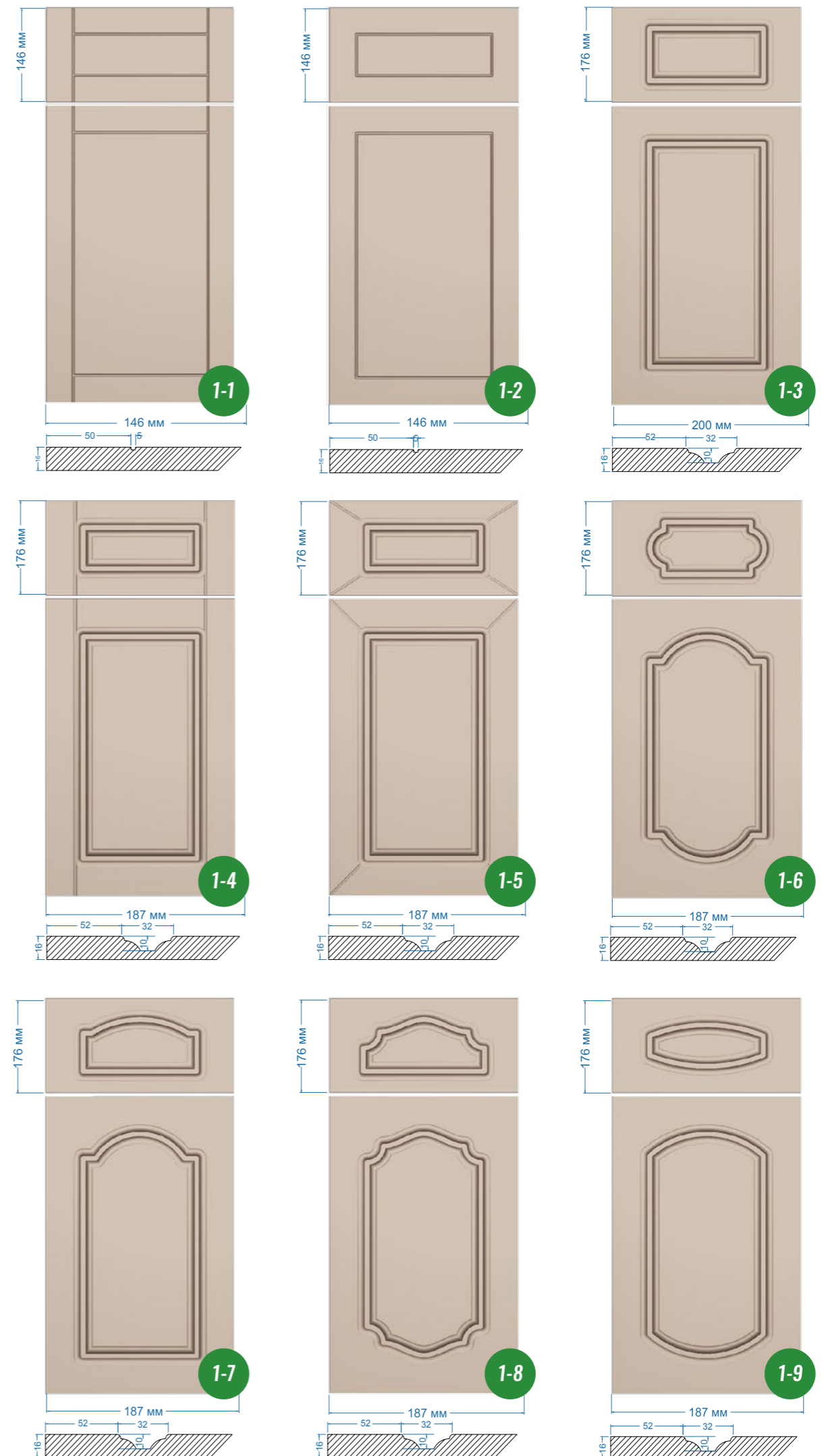
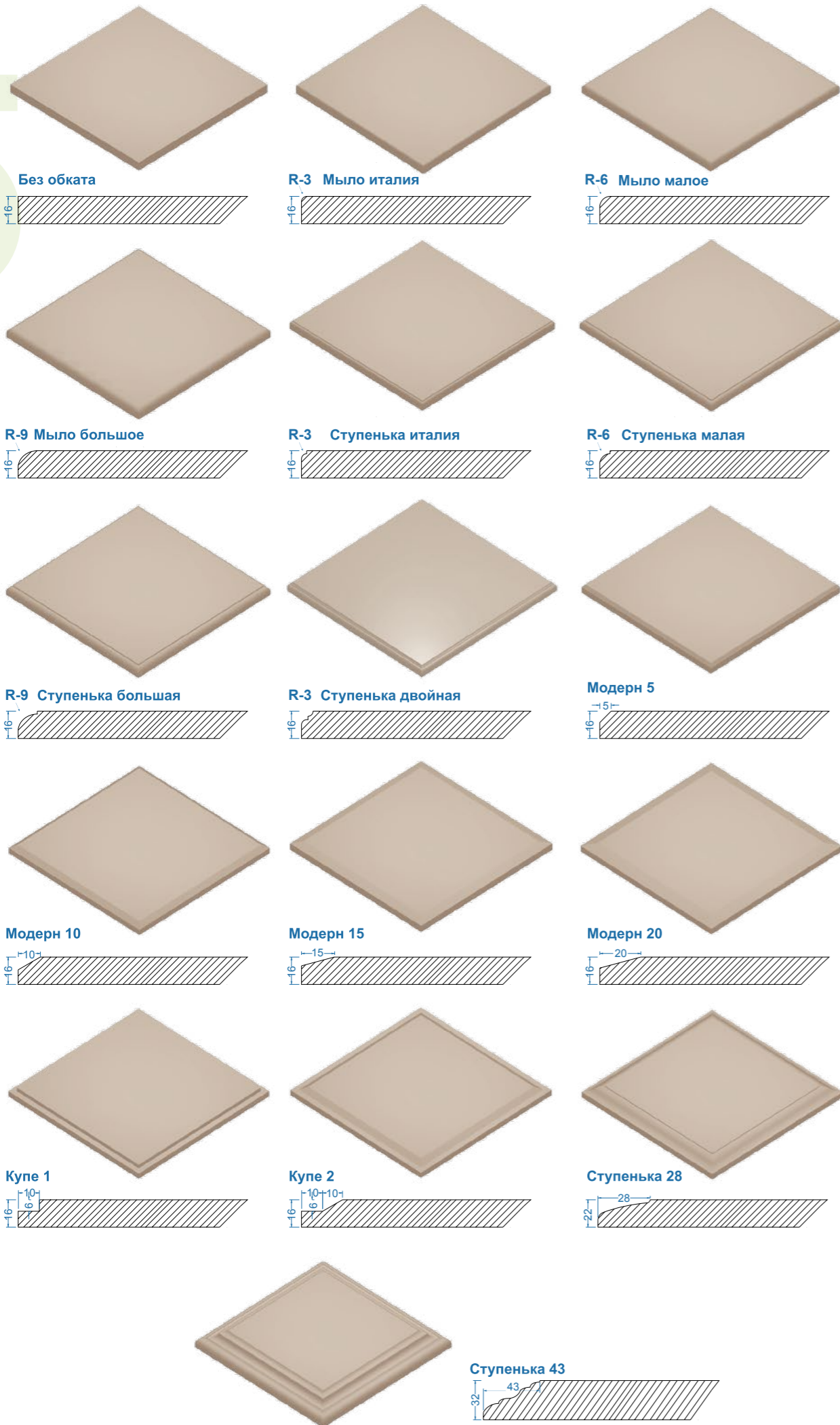



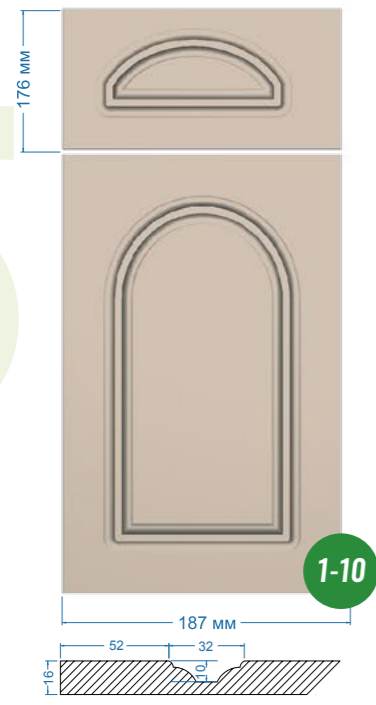

1-10



1-11



1-12

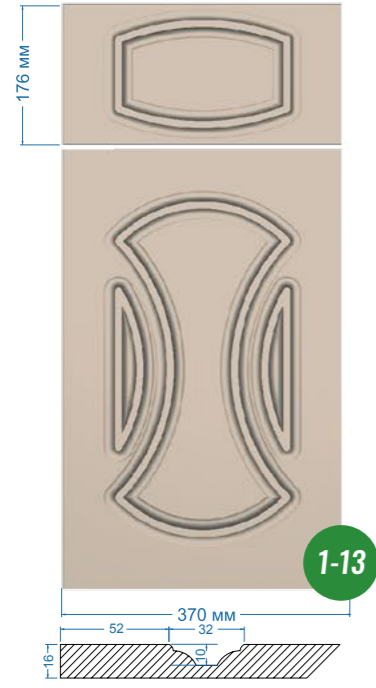

1-13

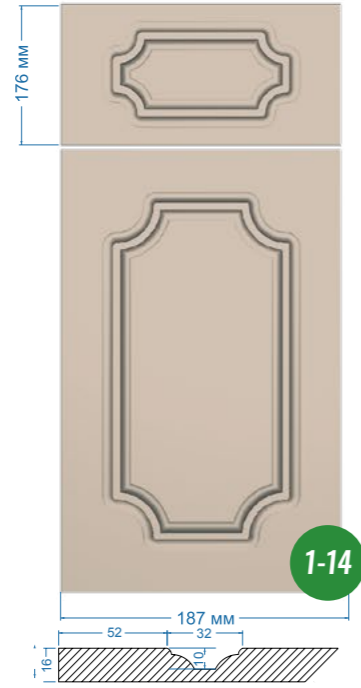

1-14

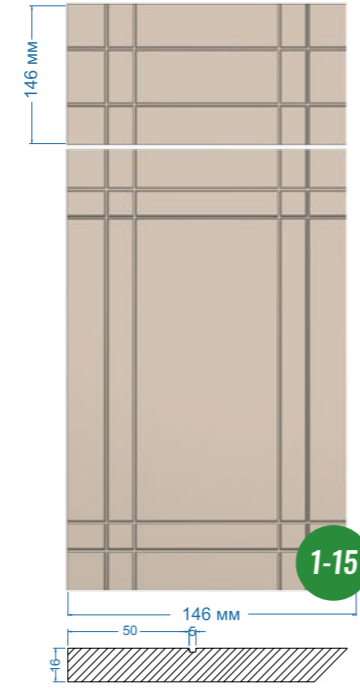

1-15

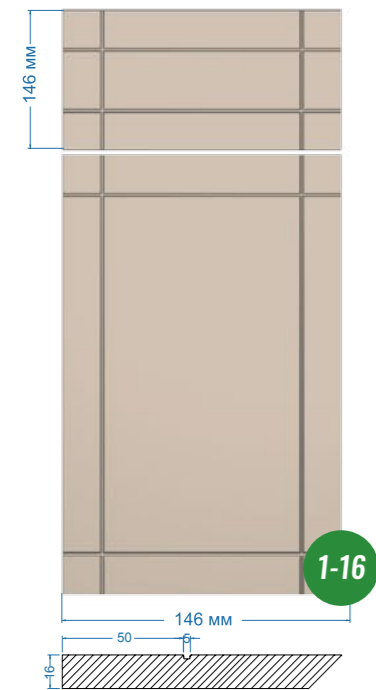

1-16

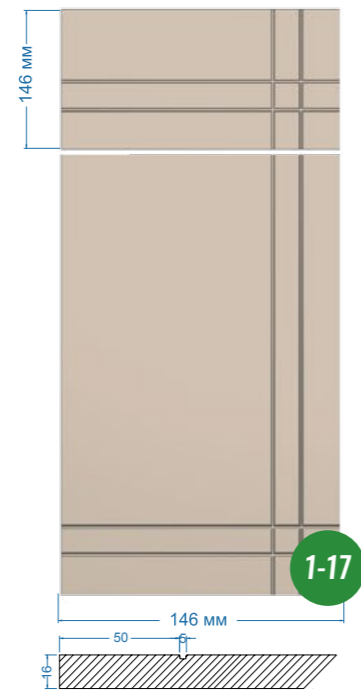

1-17



1-18

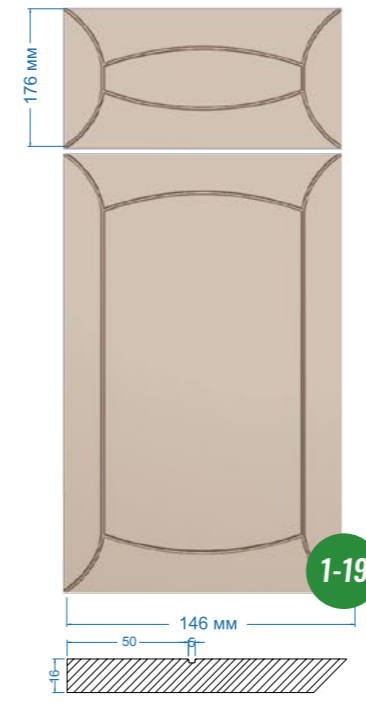

1-19

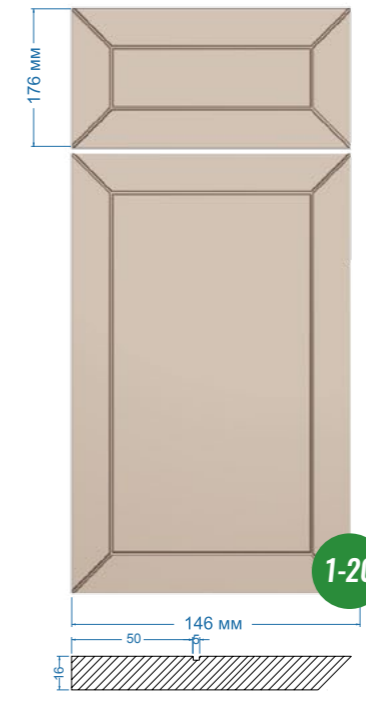

1-20

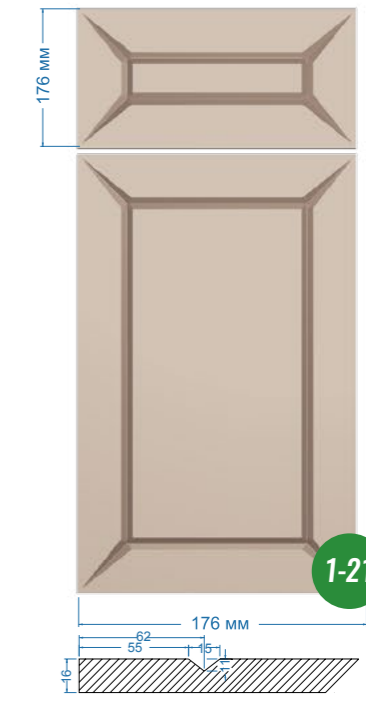

1-21

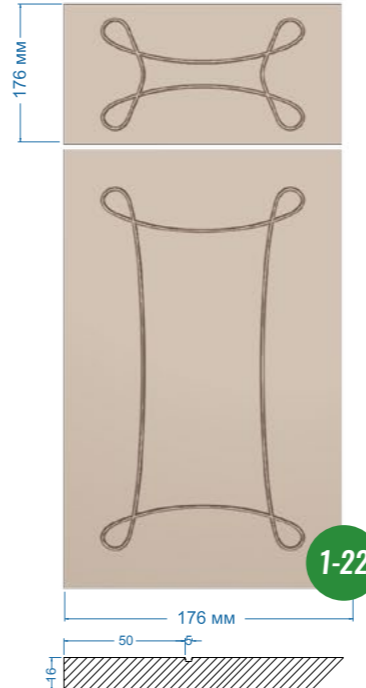

1-22

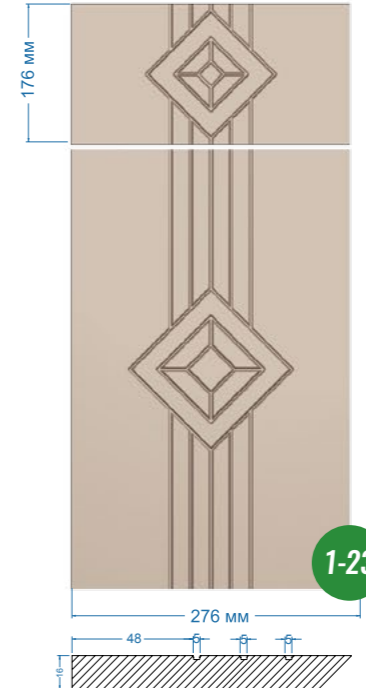

1-23



1-24



1-25

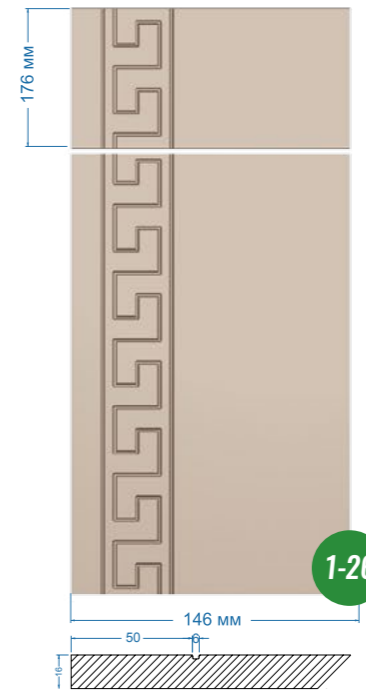

1-26



1-27



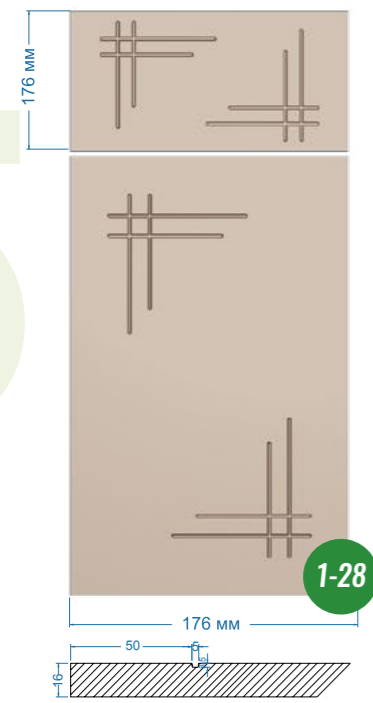

1-28

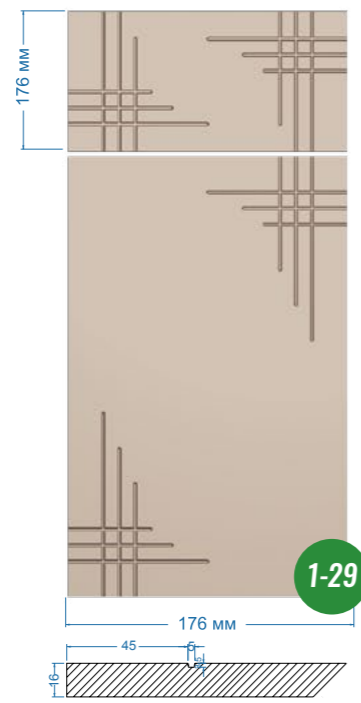

1-29

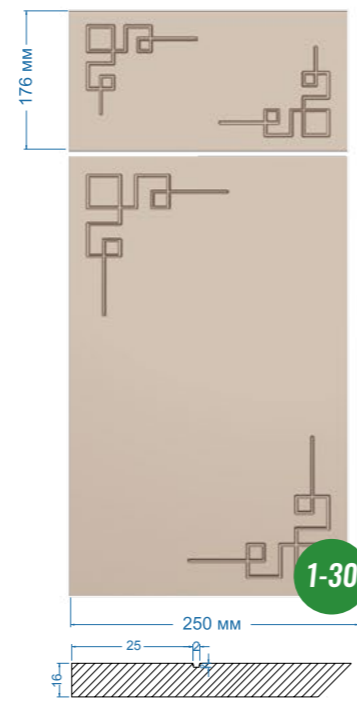

1-30

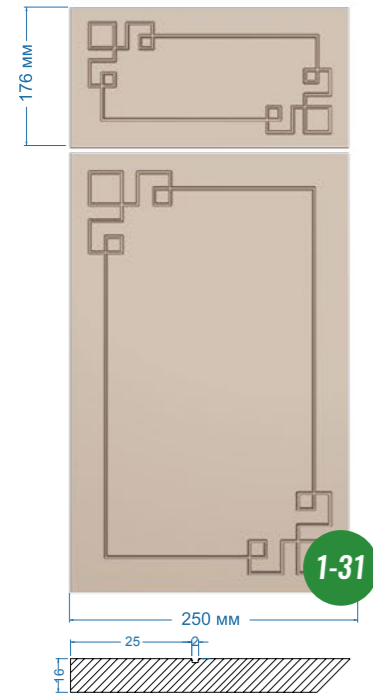

1-31



1-32



1-33



1-34

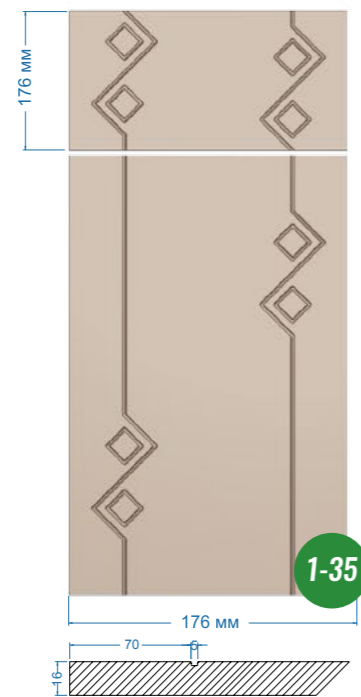

1-35

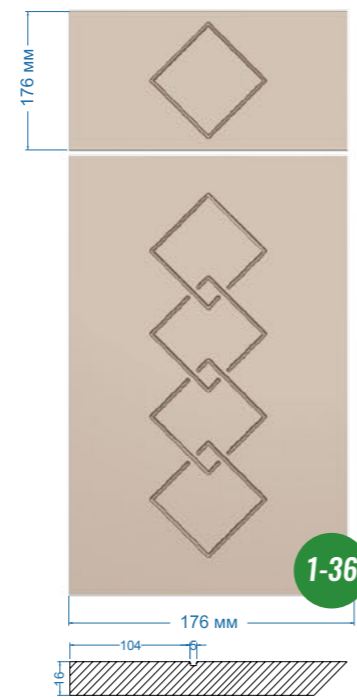

1-36

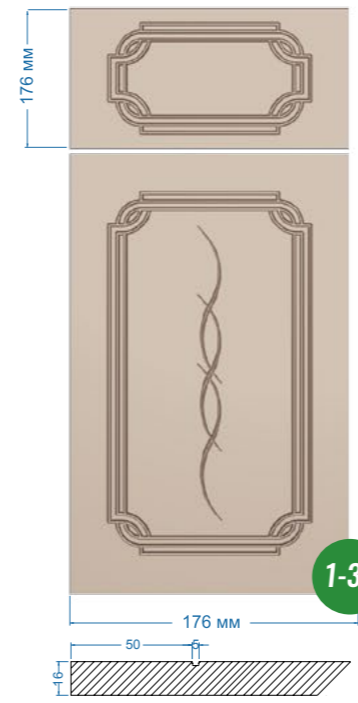

1-37

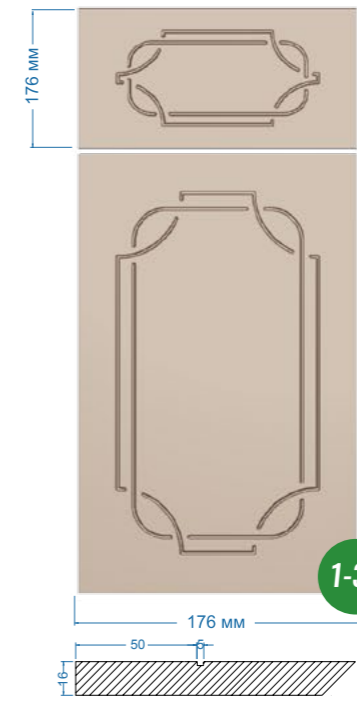

1-38

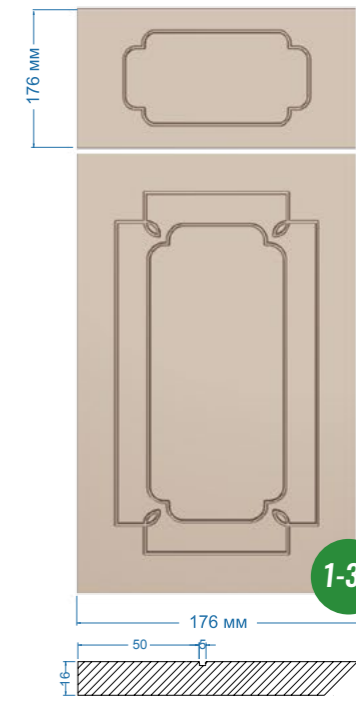

1-39

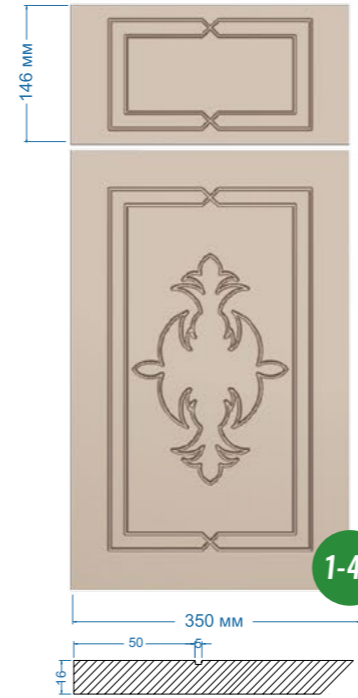

1-40

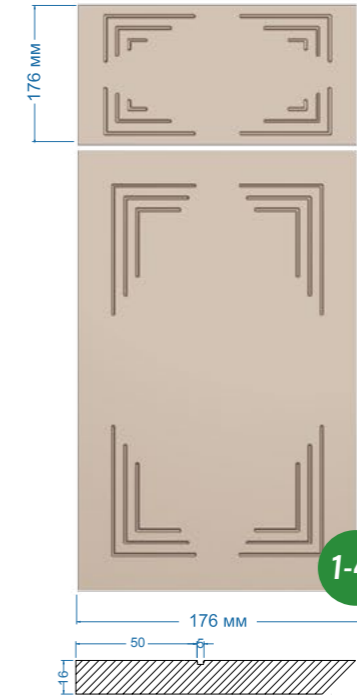

1-41

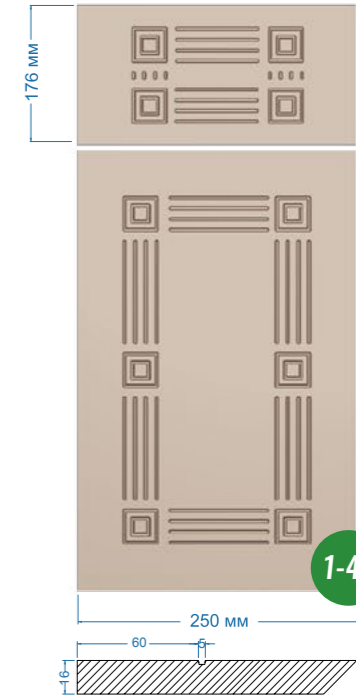

1-42



1-43



1-44

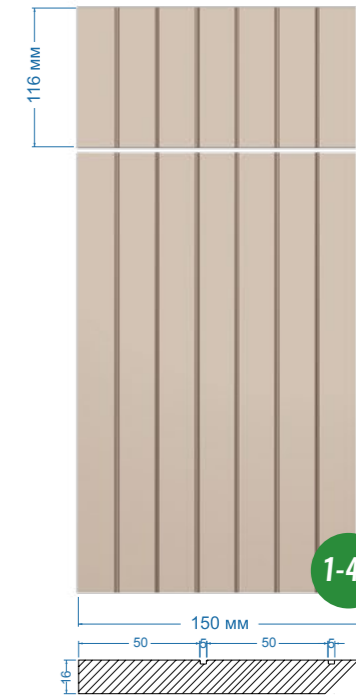

1-45



2-1



2-2



2-3

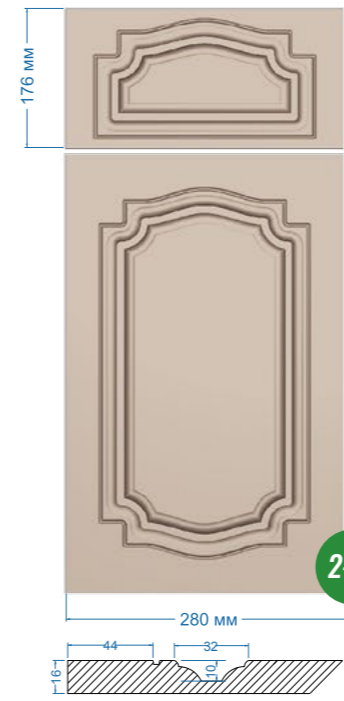

2-10



2-11



2-12

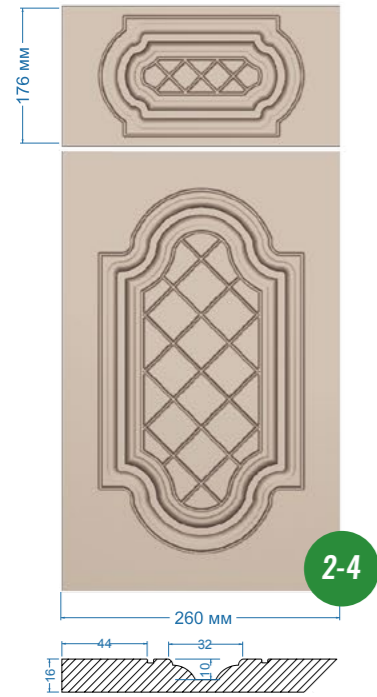

2-4



2-5

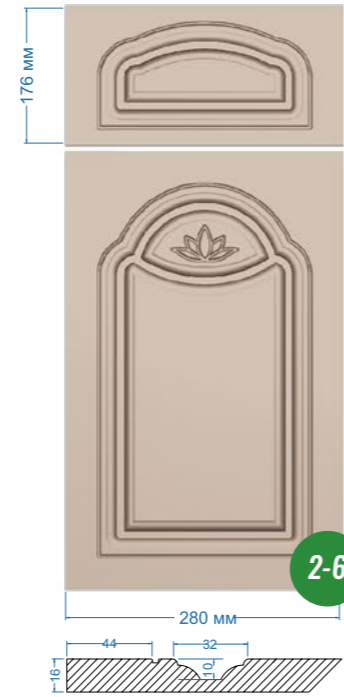

2-6



2-13

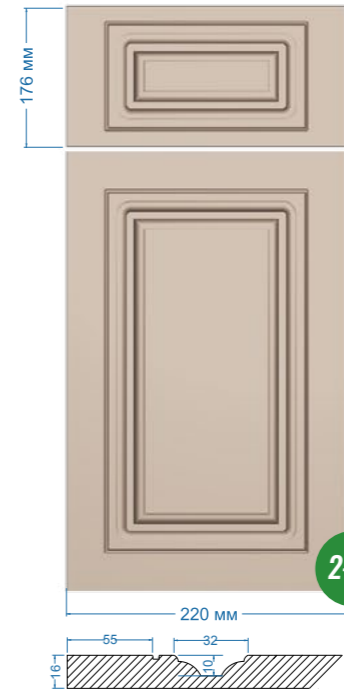

2-14

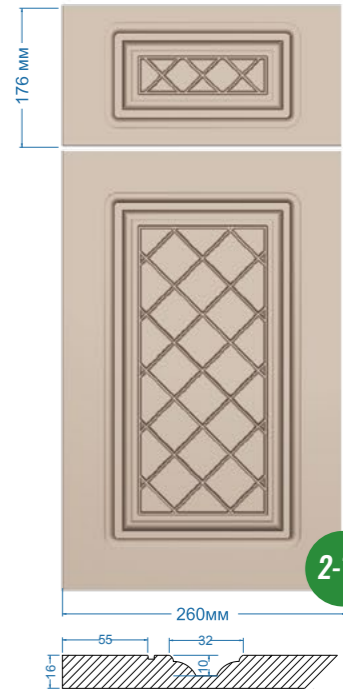

2-15



2-7



2-8



2-9

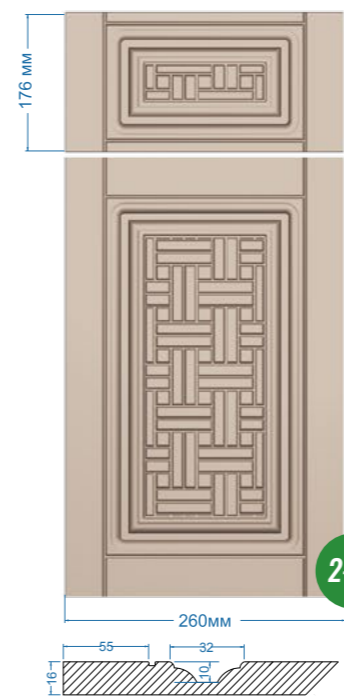

2-16

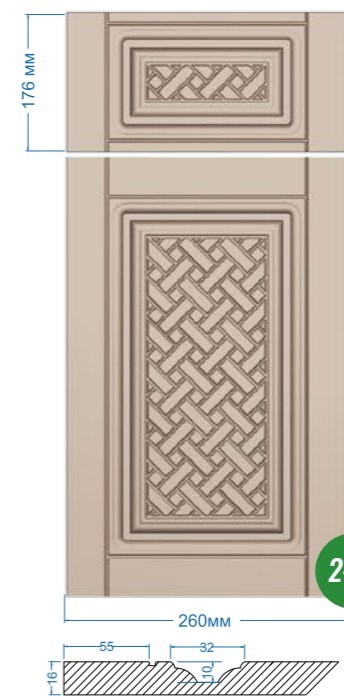

2-17

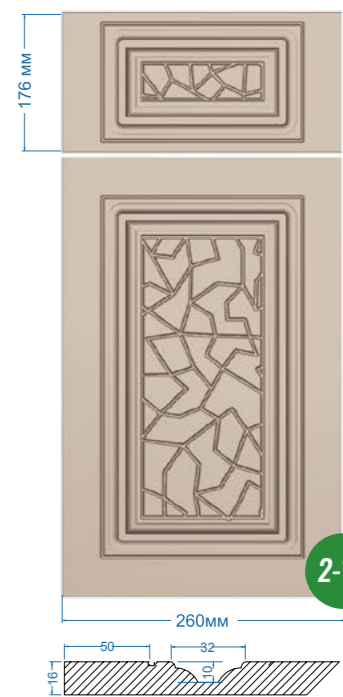

2-18



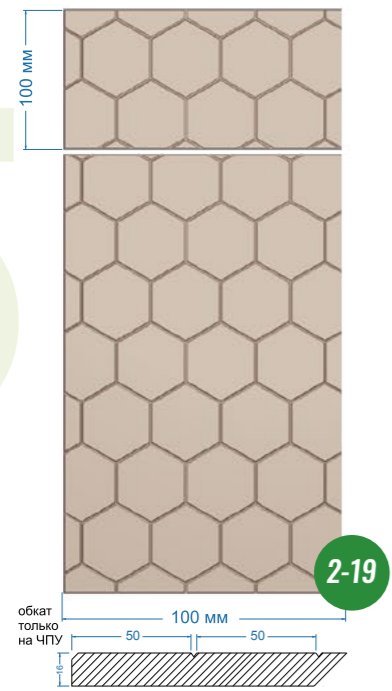

2-19

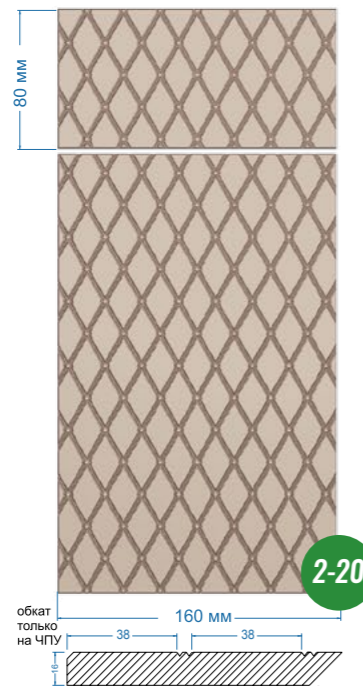

2-20



2-21



2-22



2-23



2-24

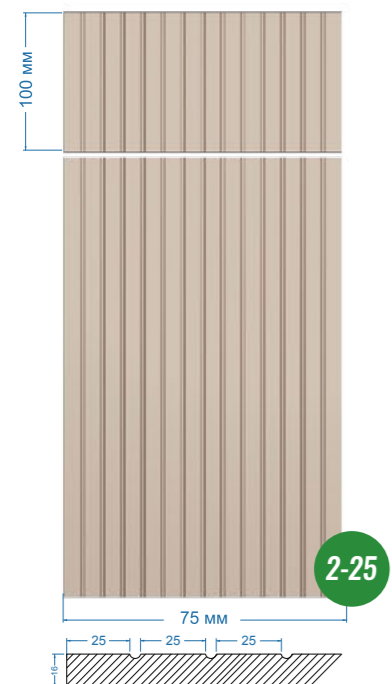

2-25



2-26

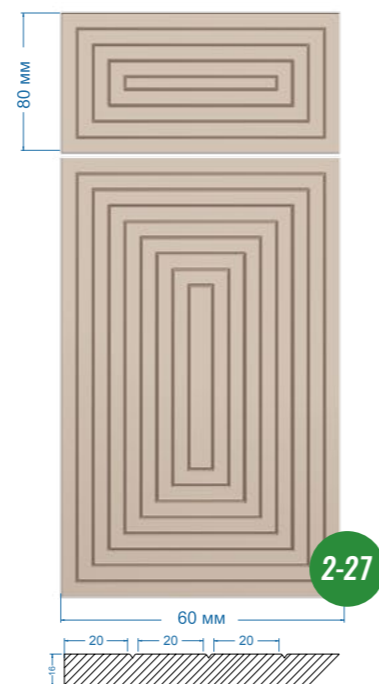

2-27

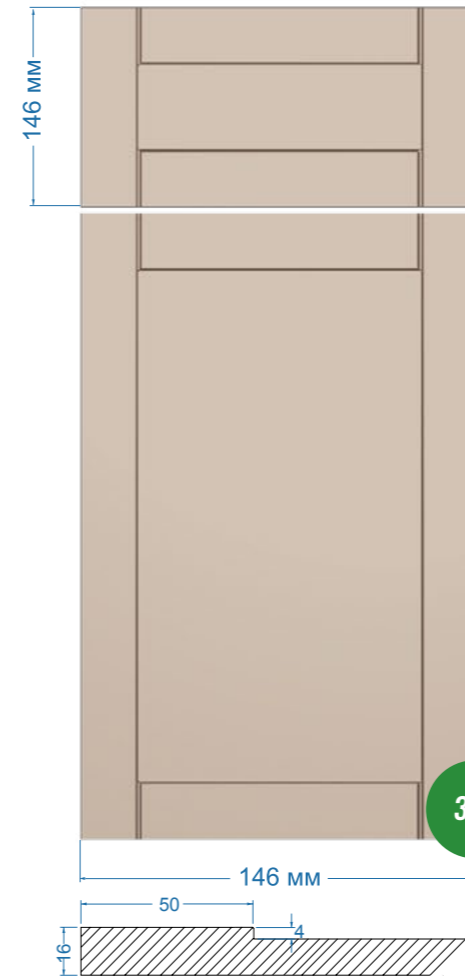

3-1

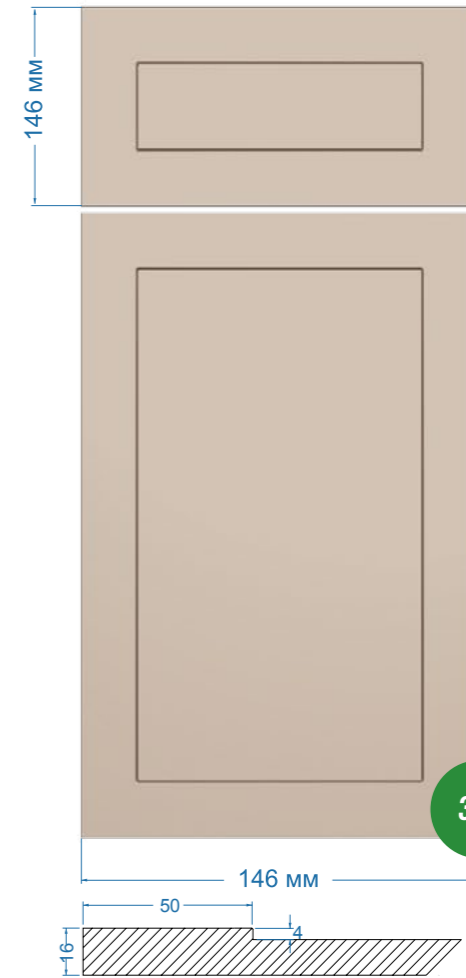

3-2

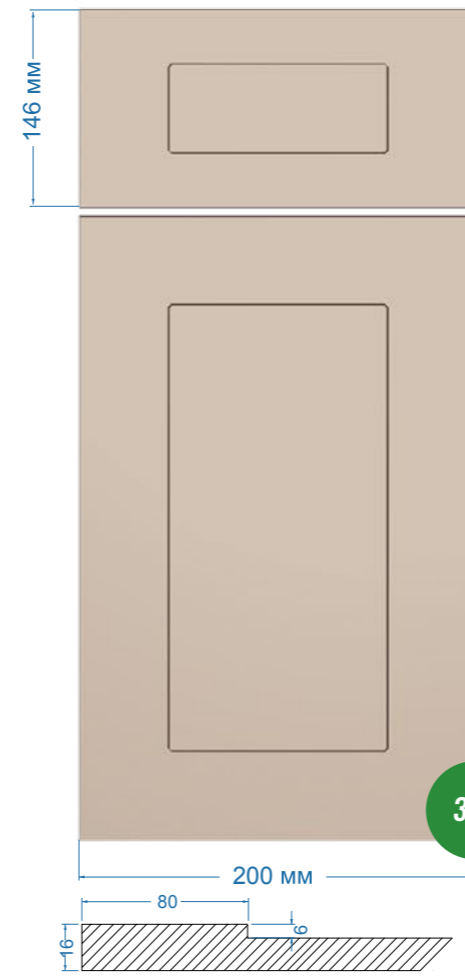

3-3

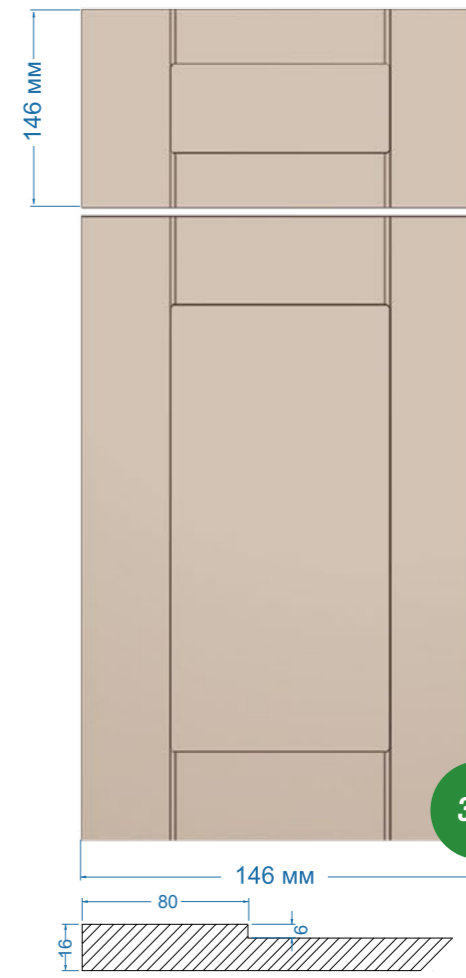

3-4



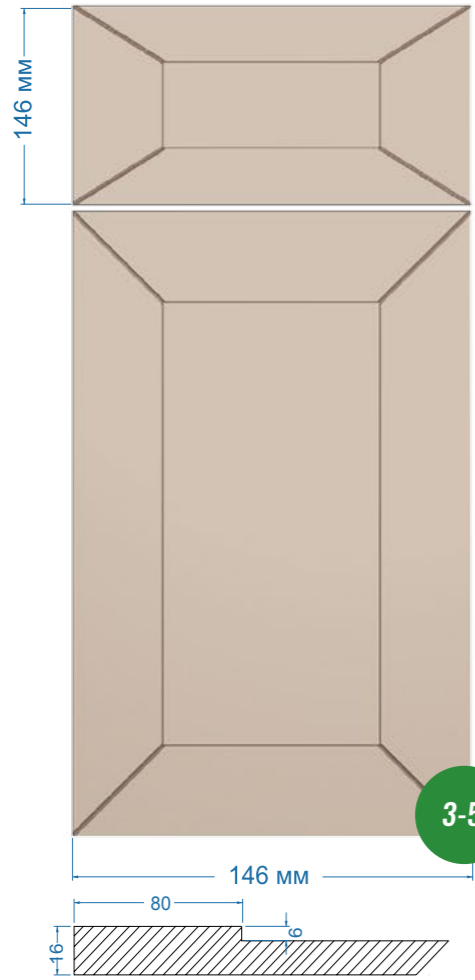

3-5

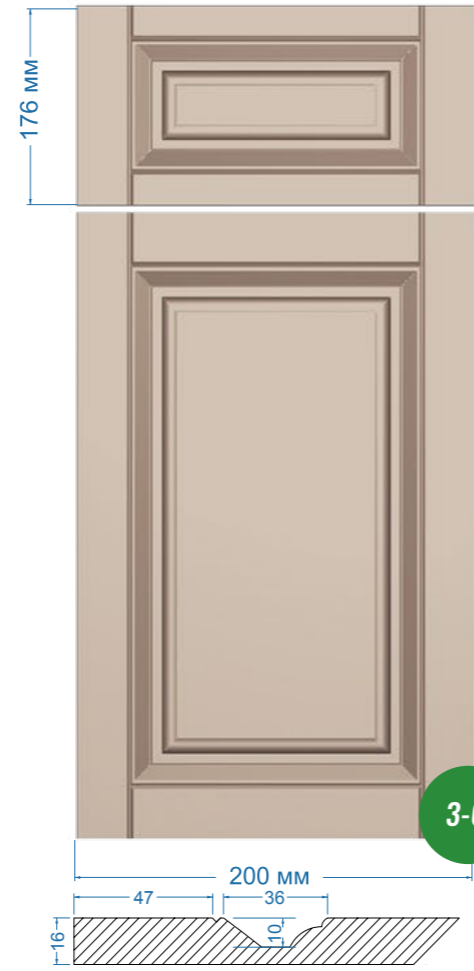

3-6

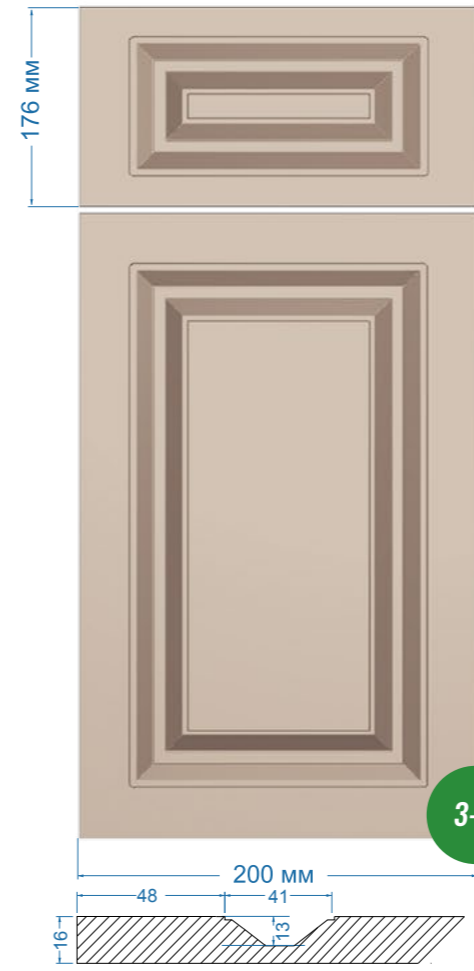

3-9

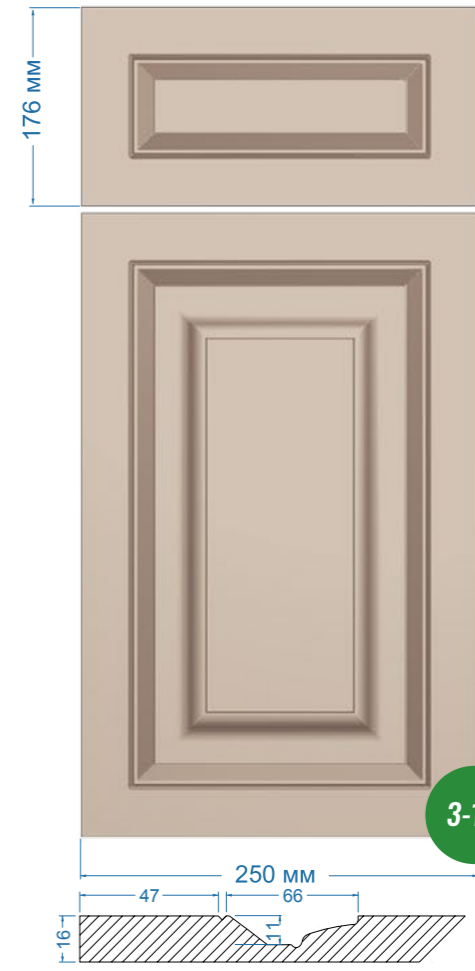

3-10

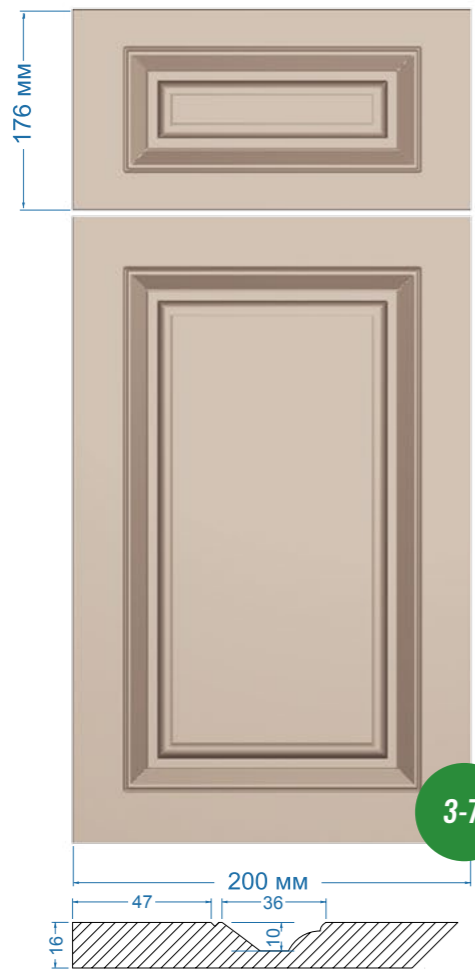

3-7

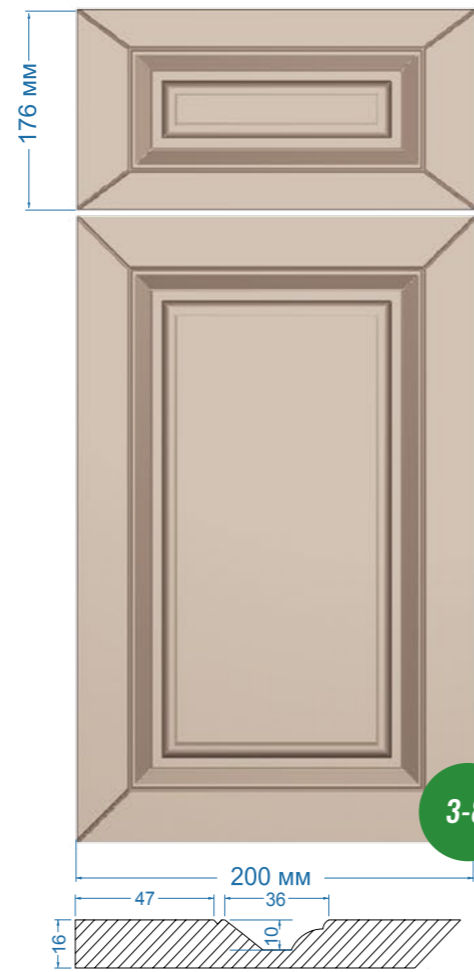

3-8



3-11



3-12



3-13

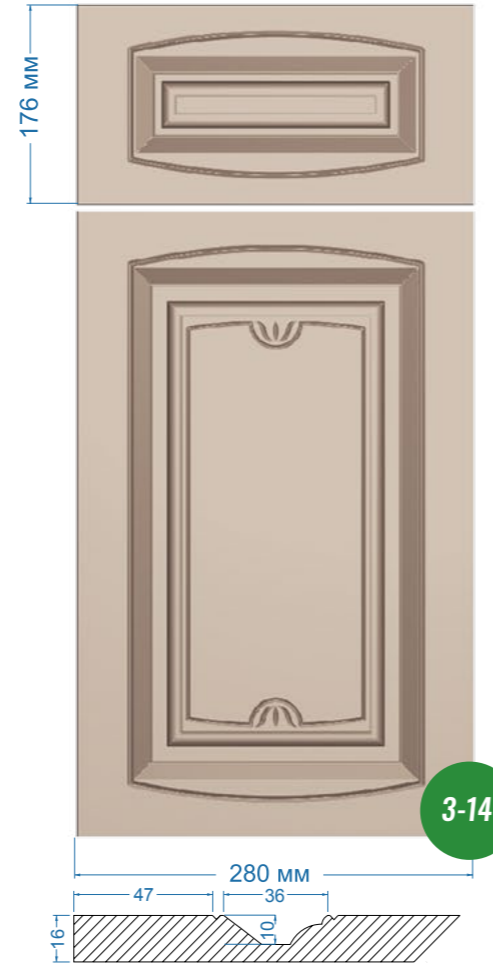

3-14



3-15

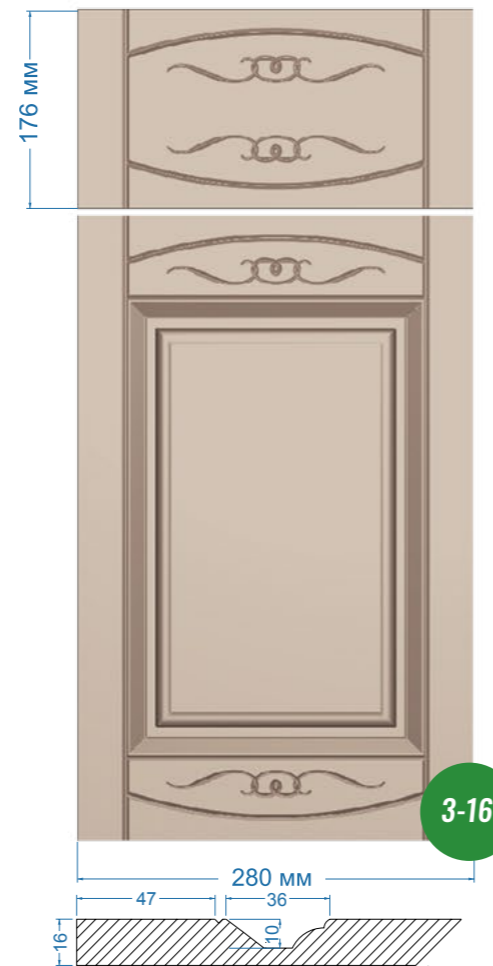

3-16



3-17

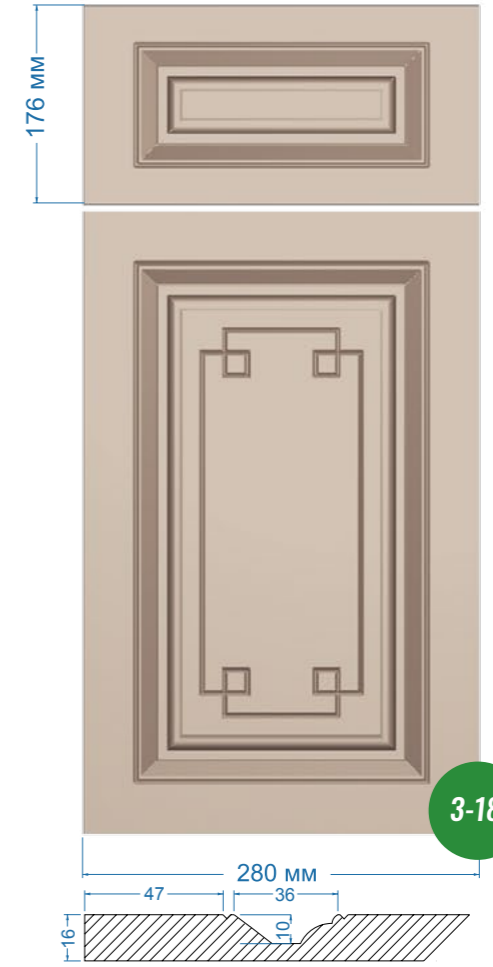

3-18

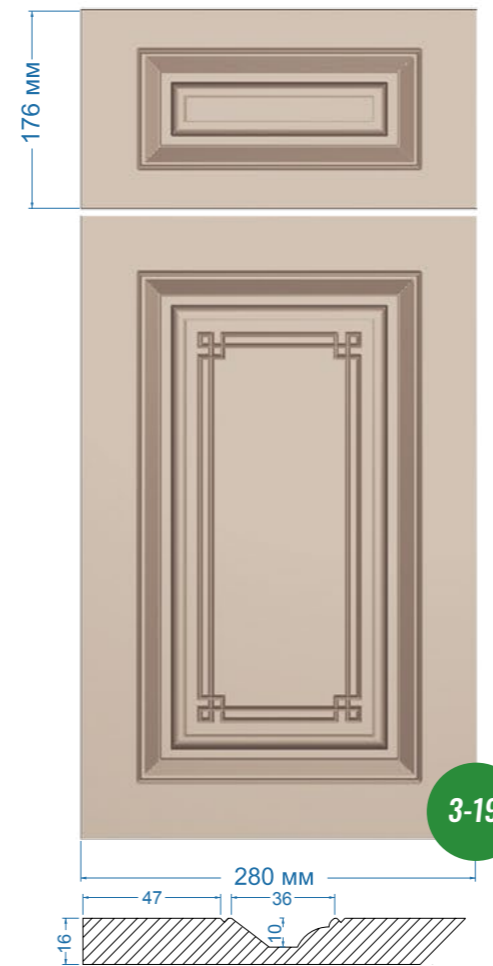

3-19



3-20

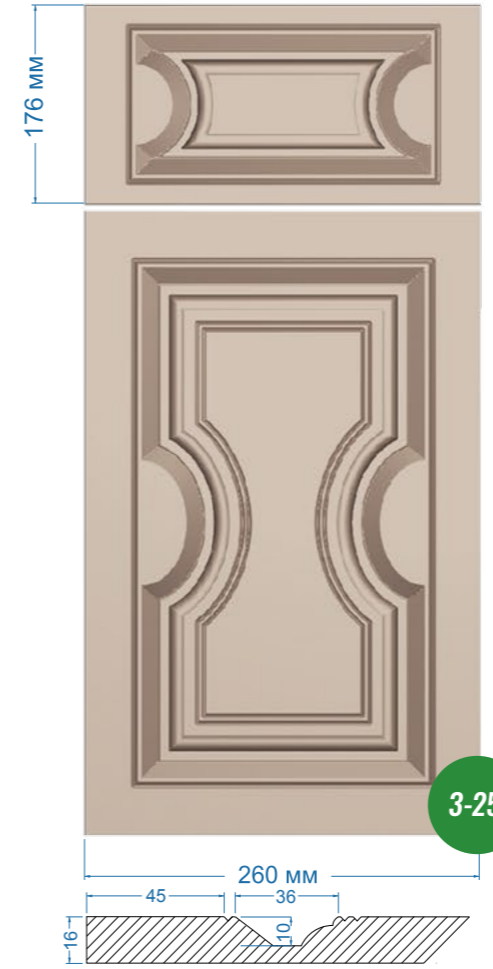
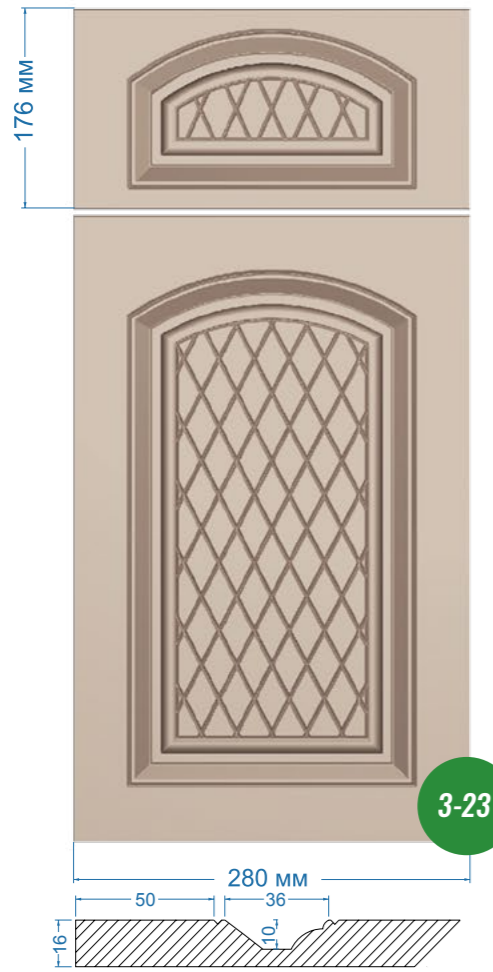
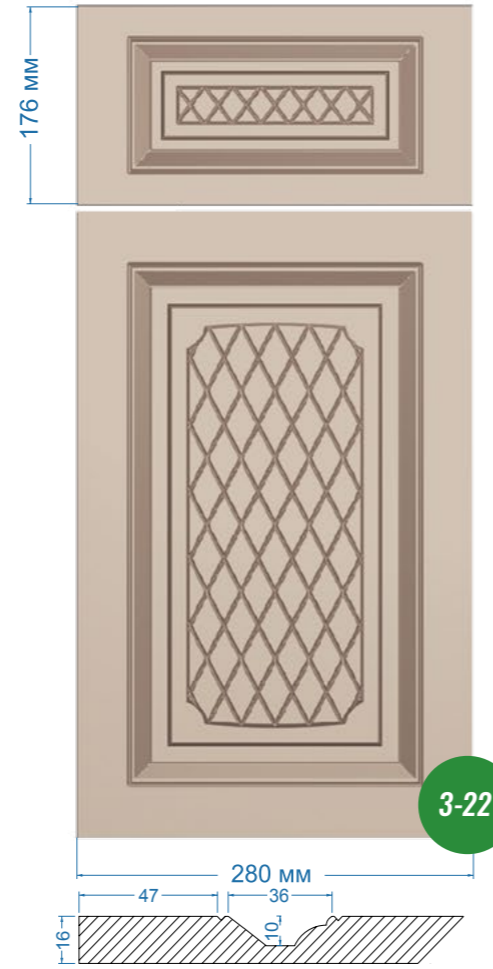
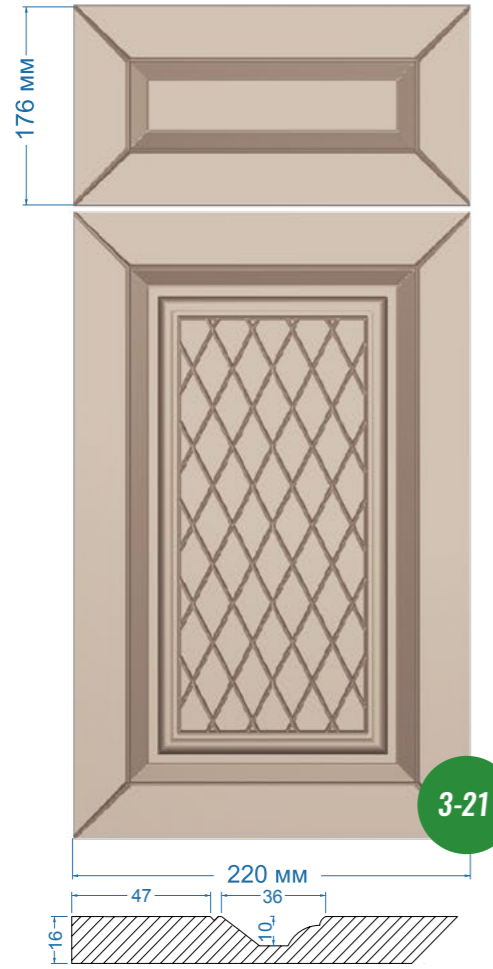



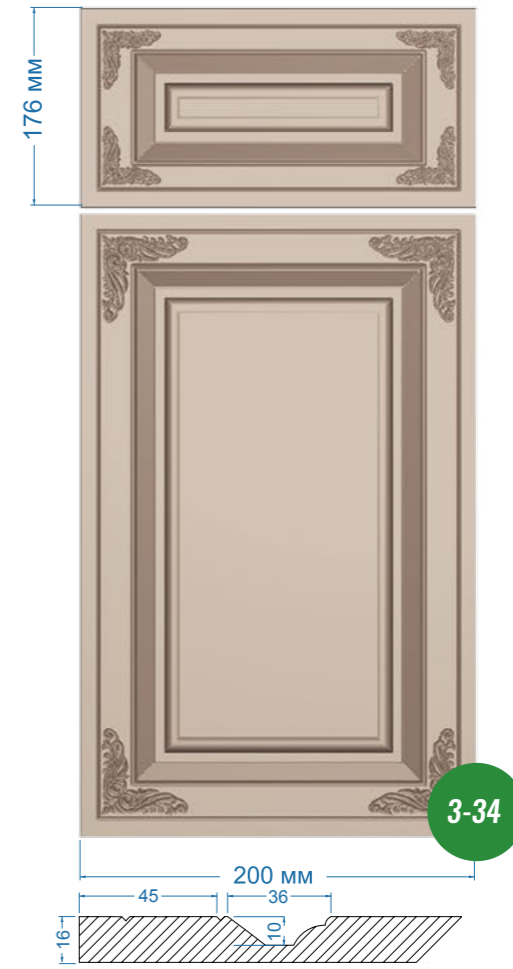
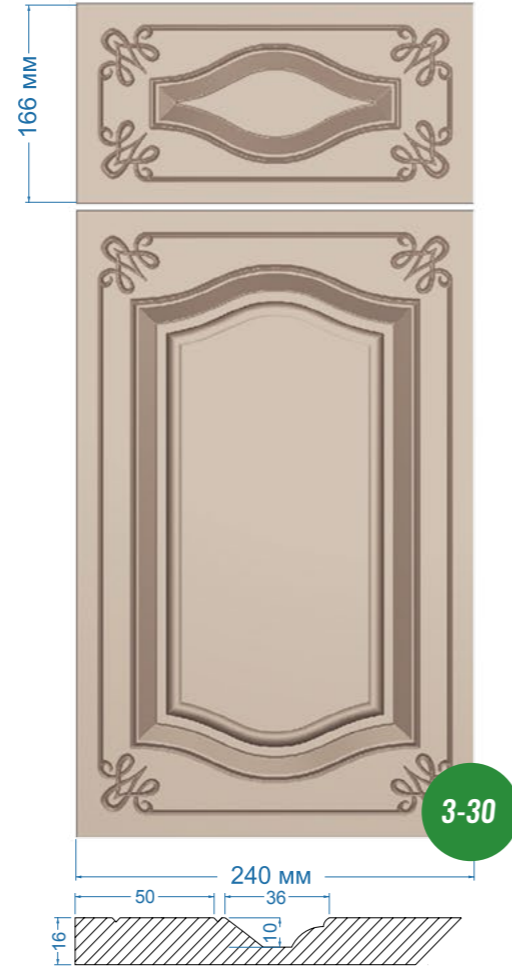
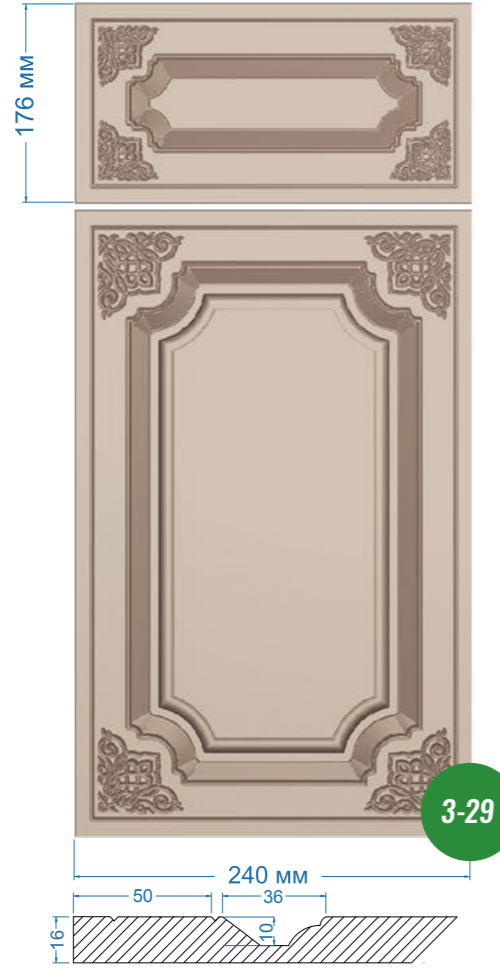

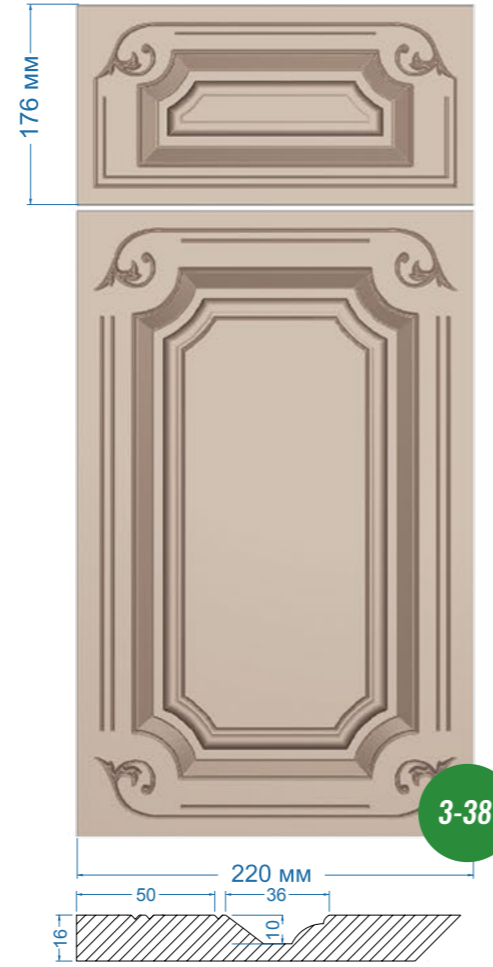
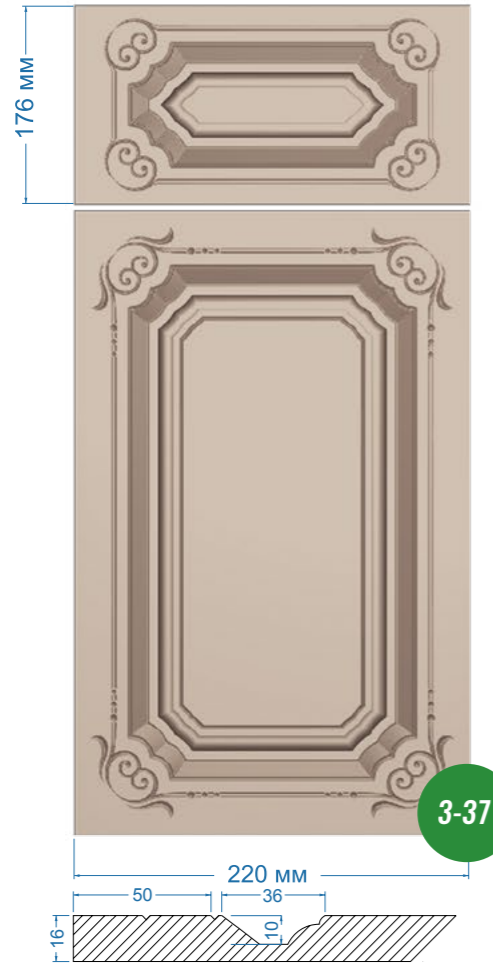

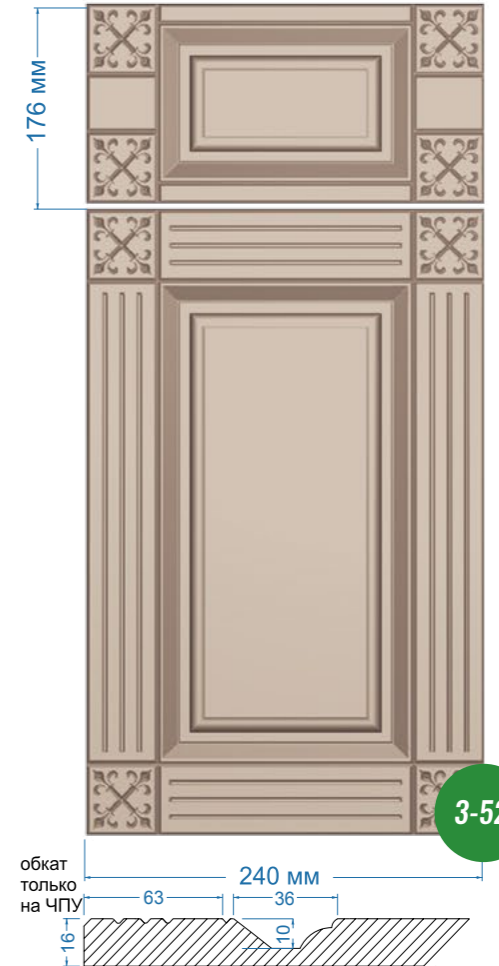
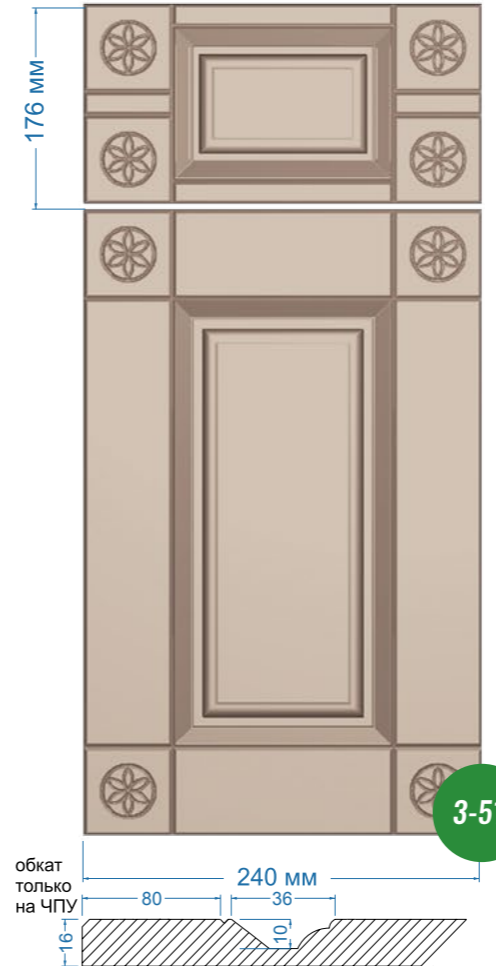
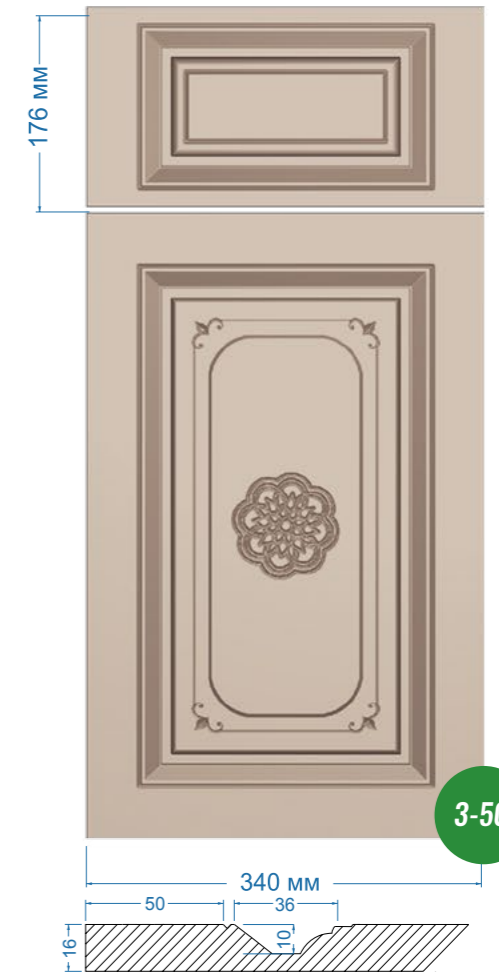
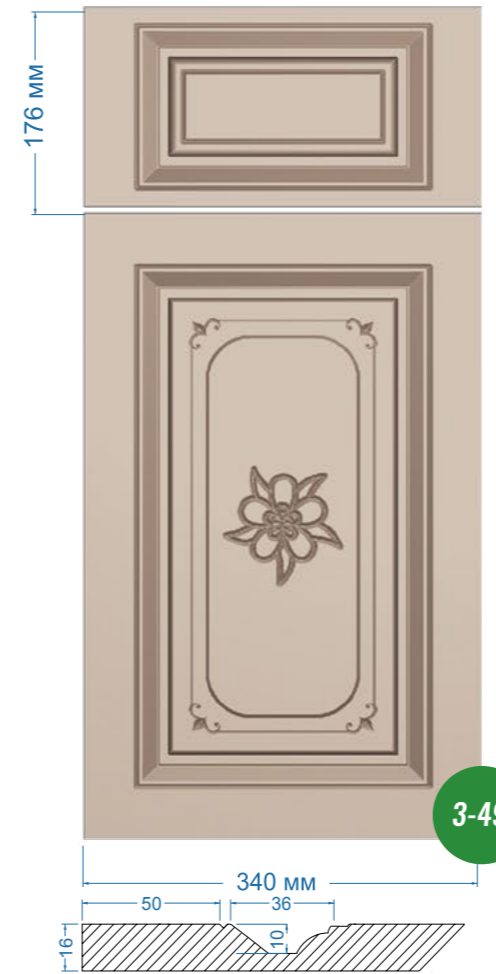
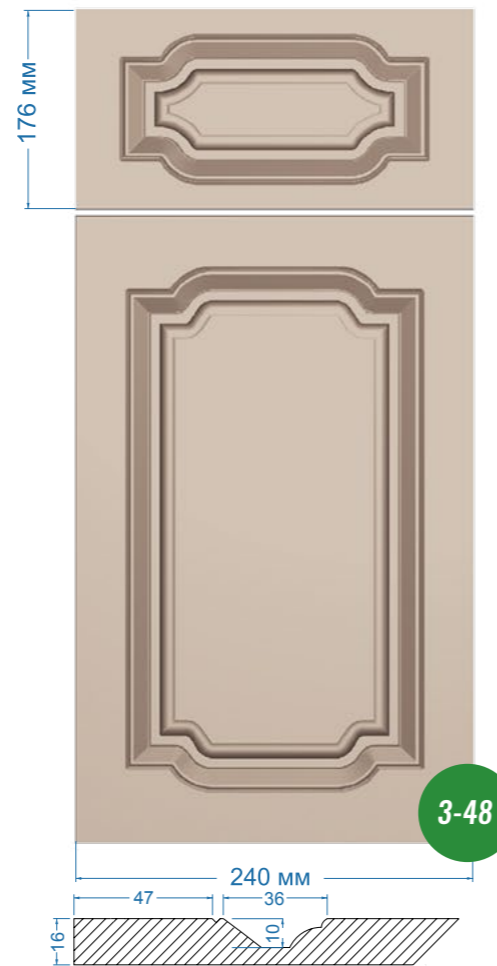
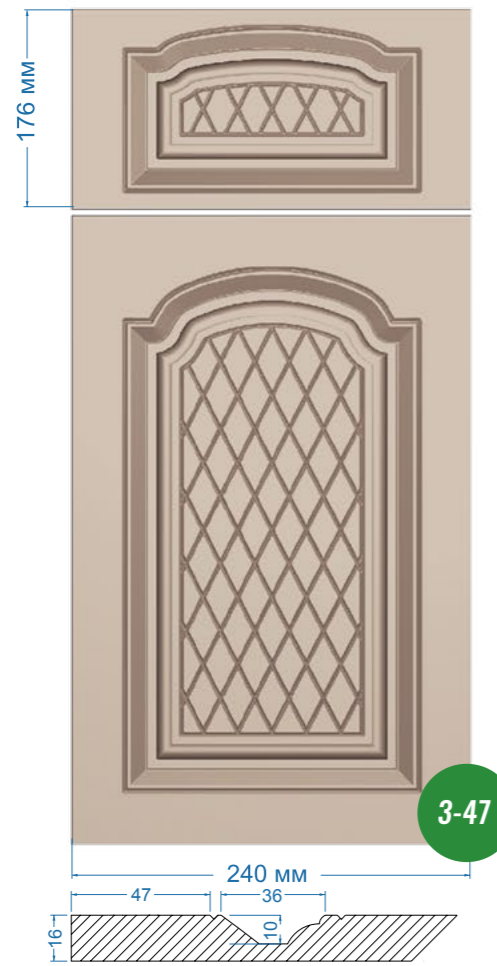
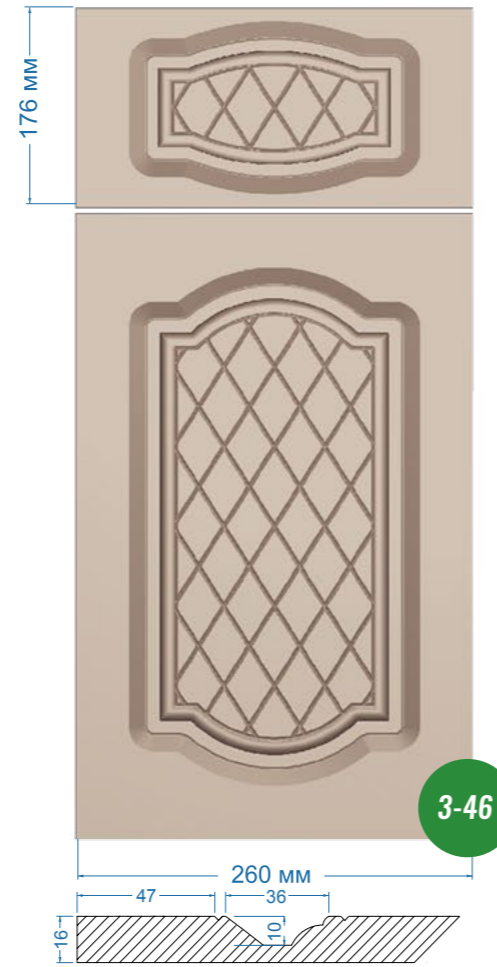
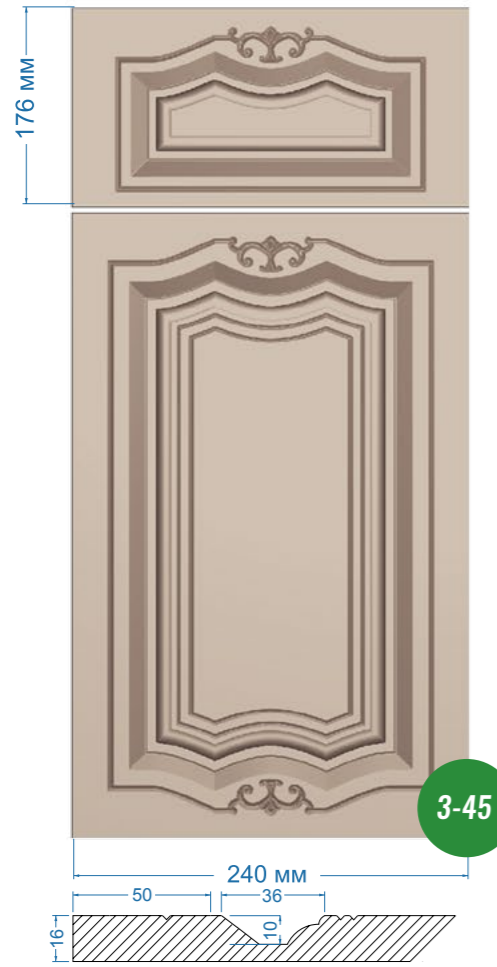



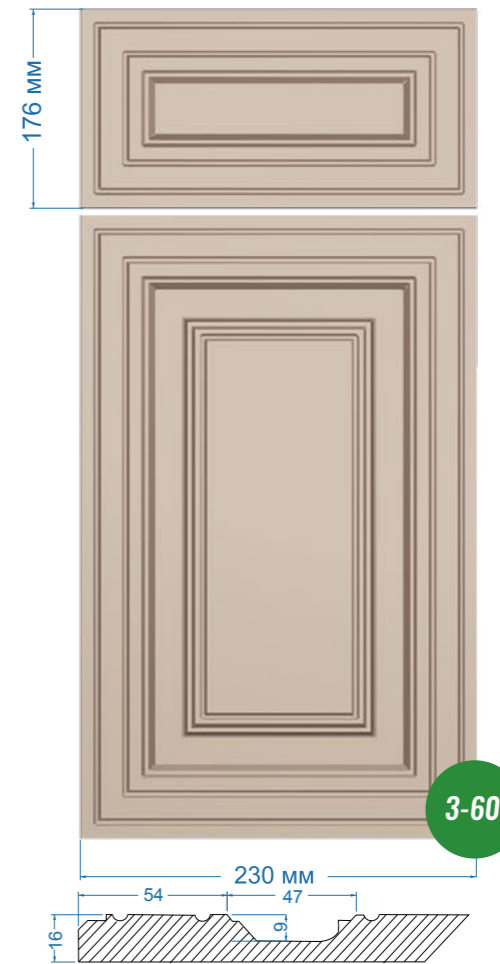
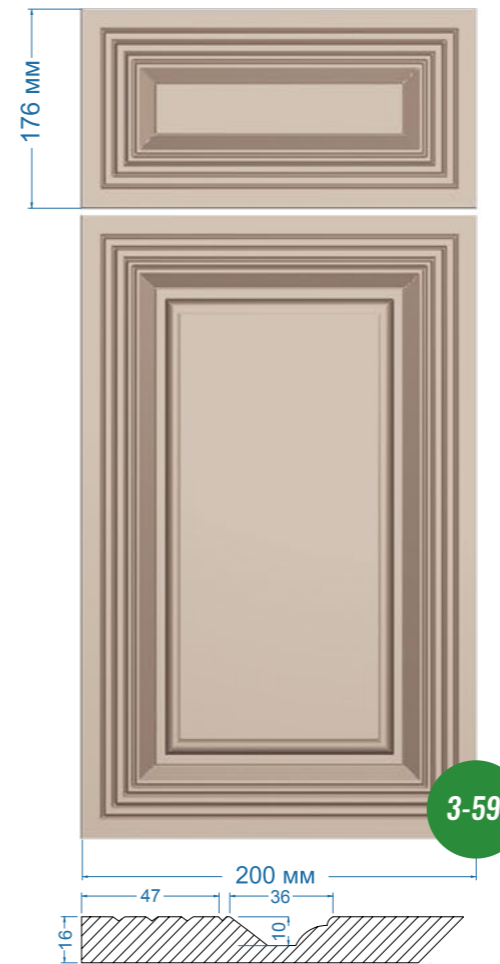
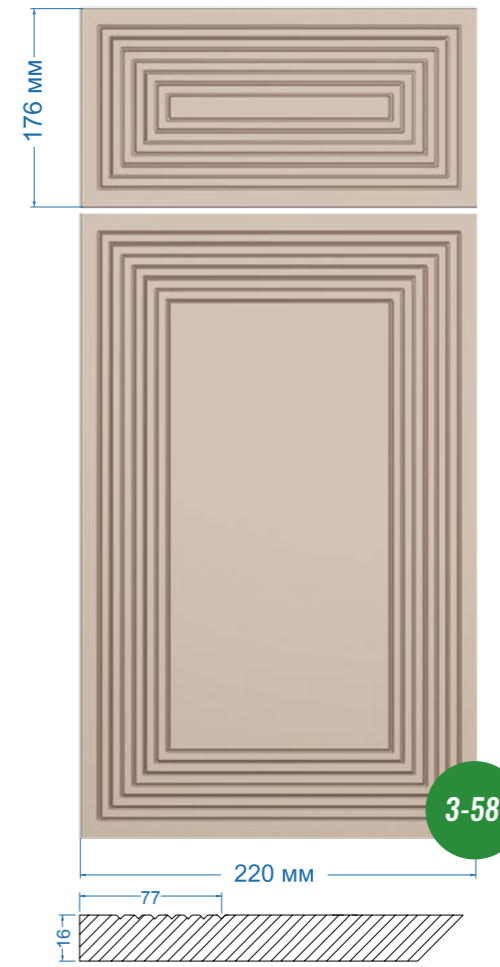
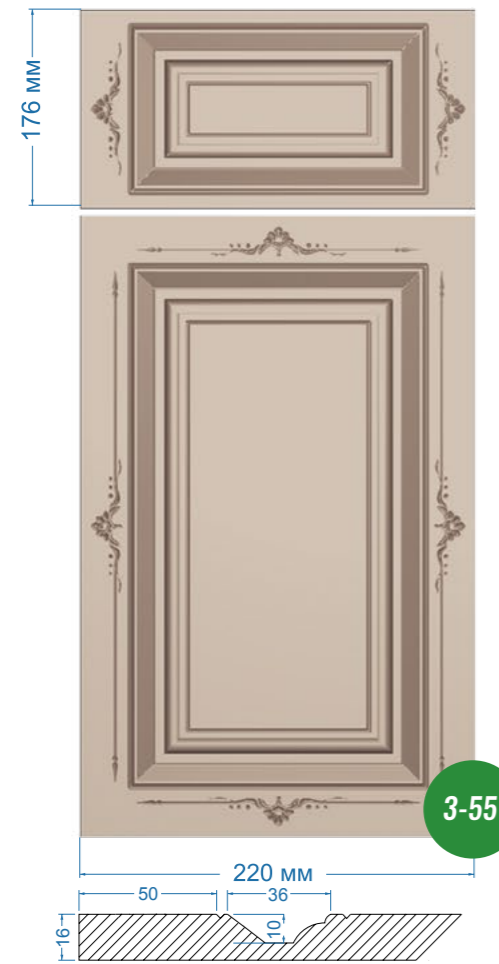
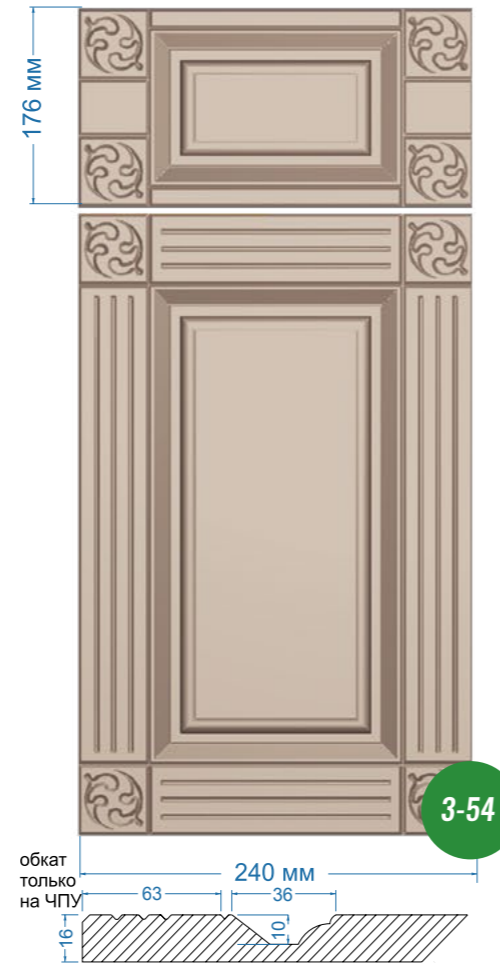
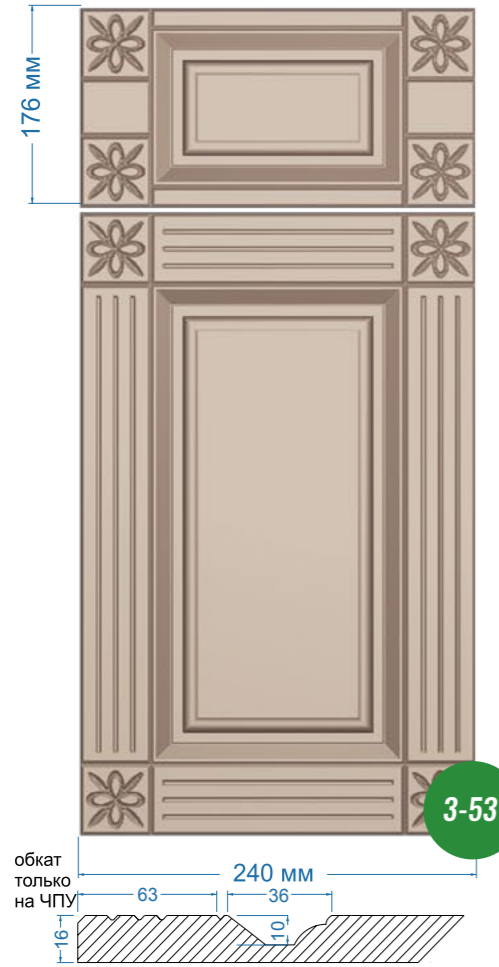

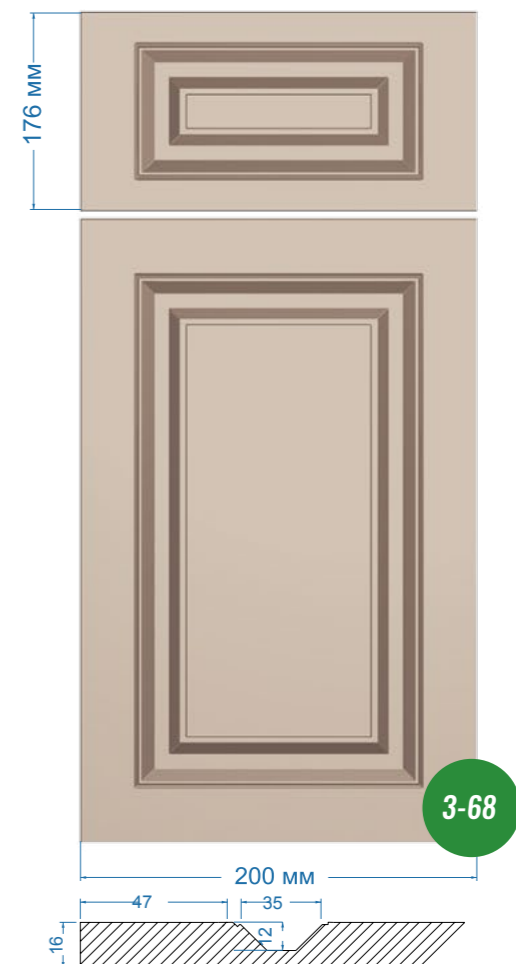
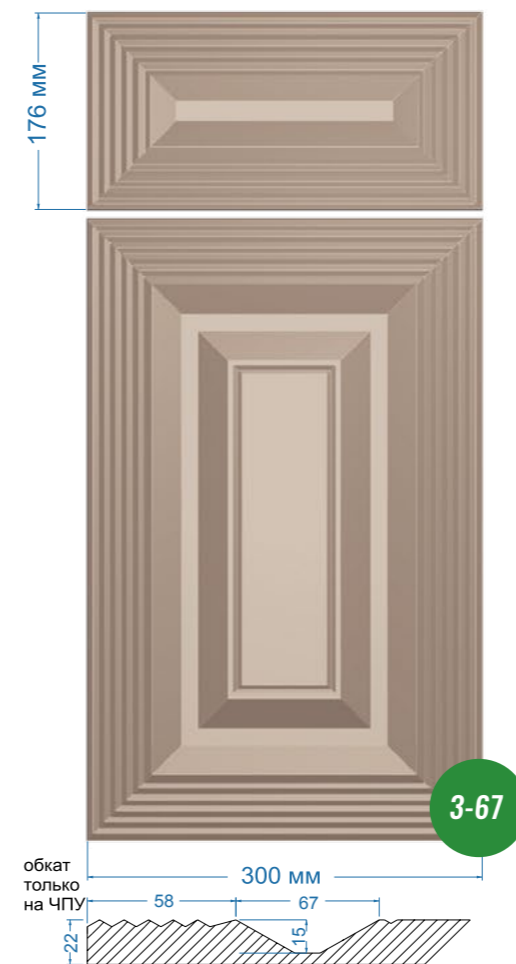
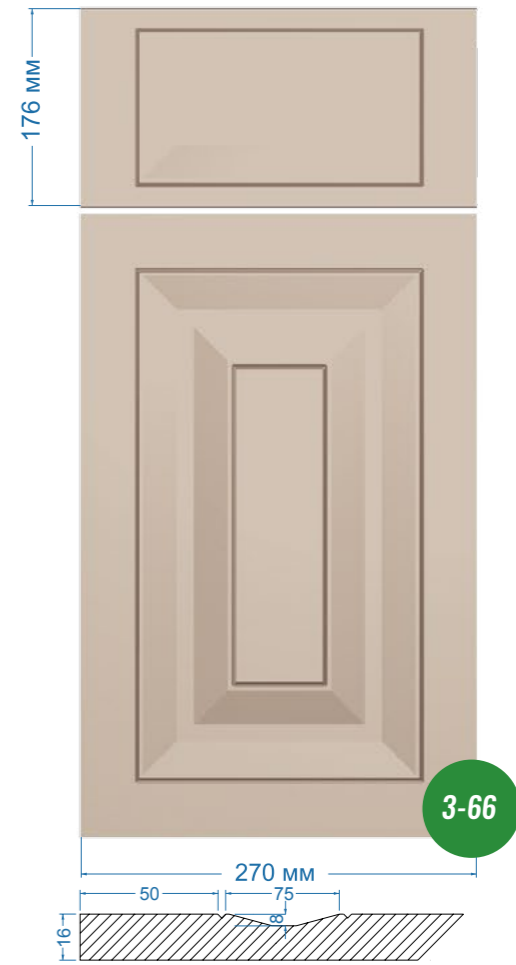
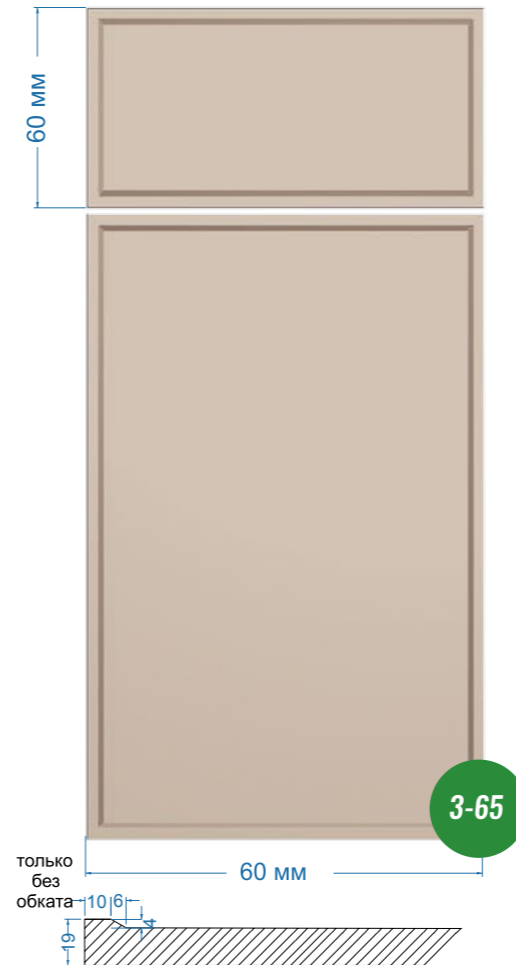
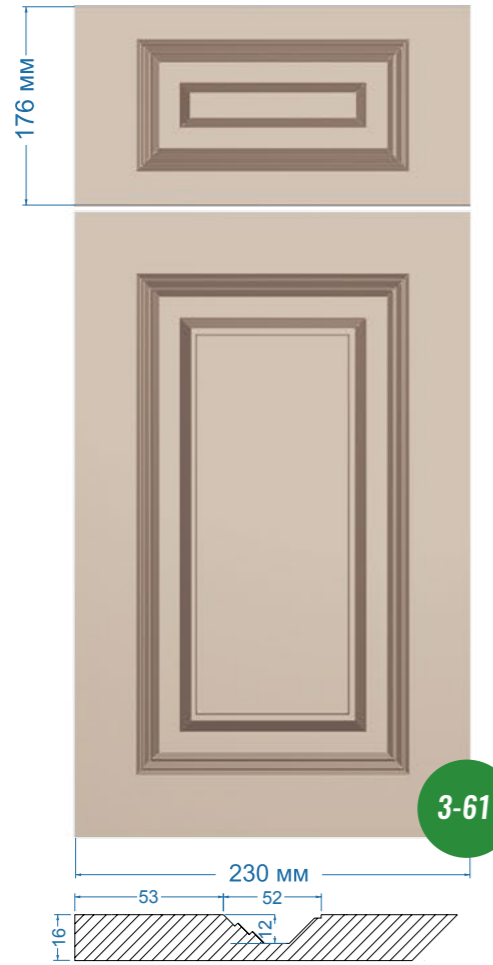

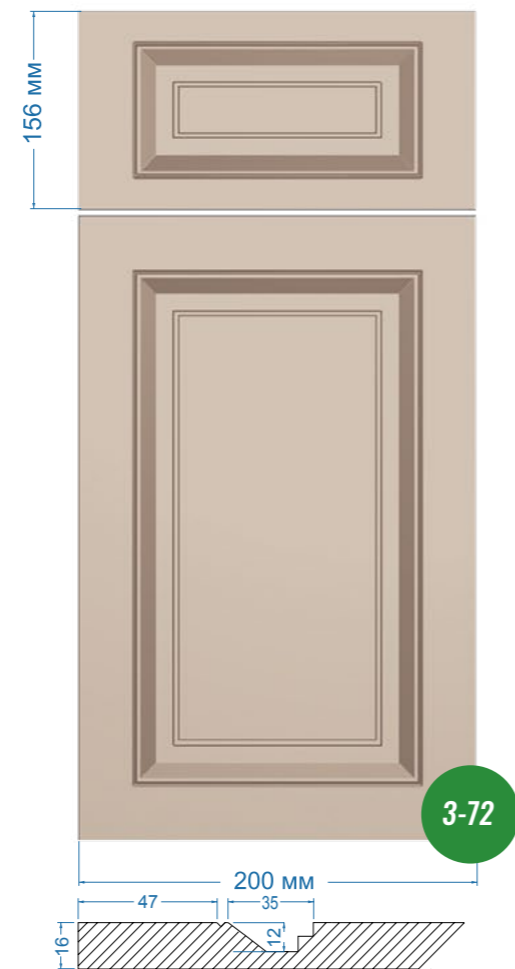
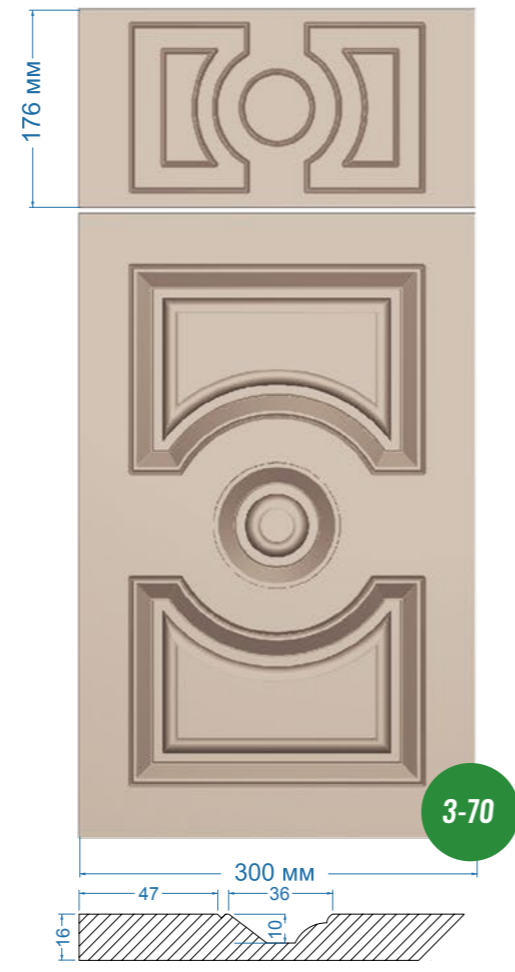
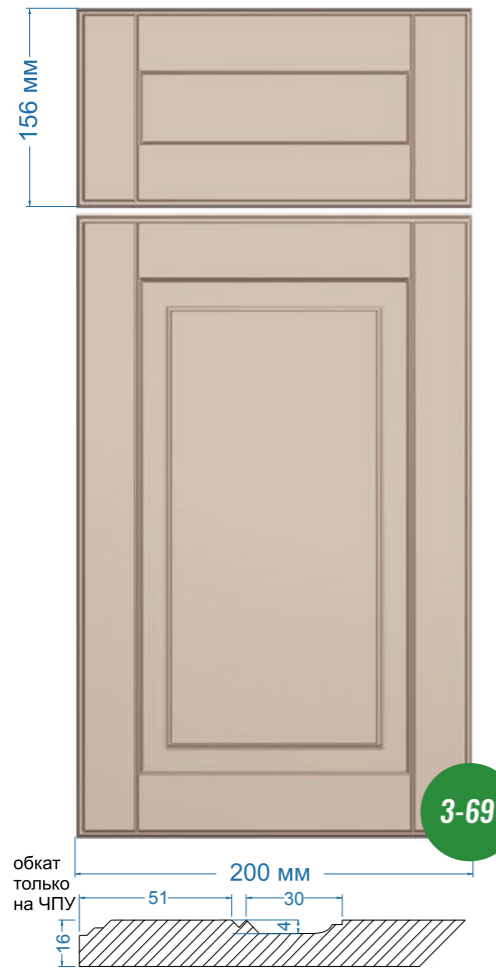



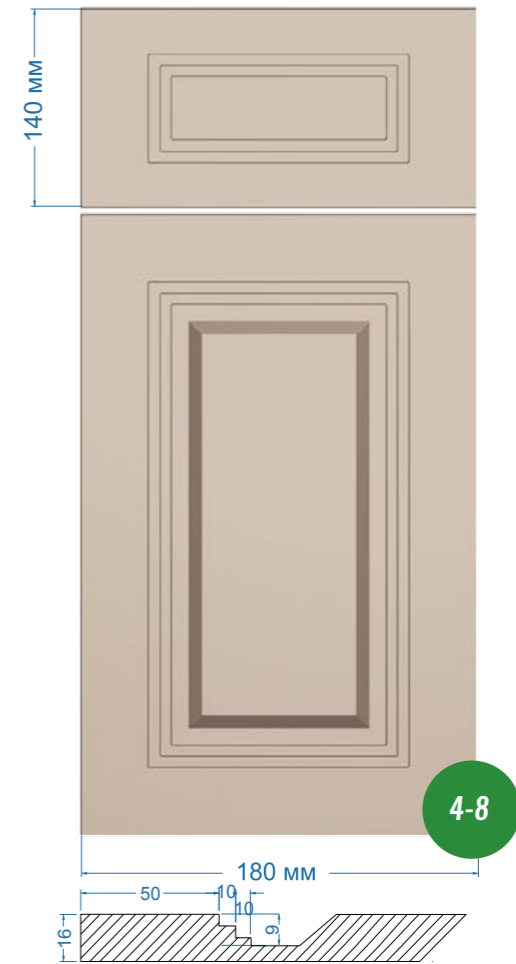
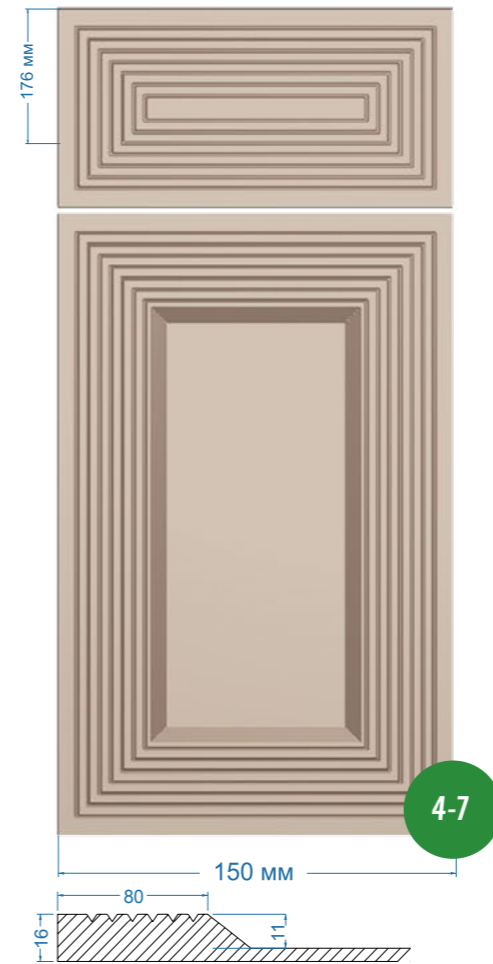
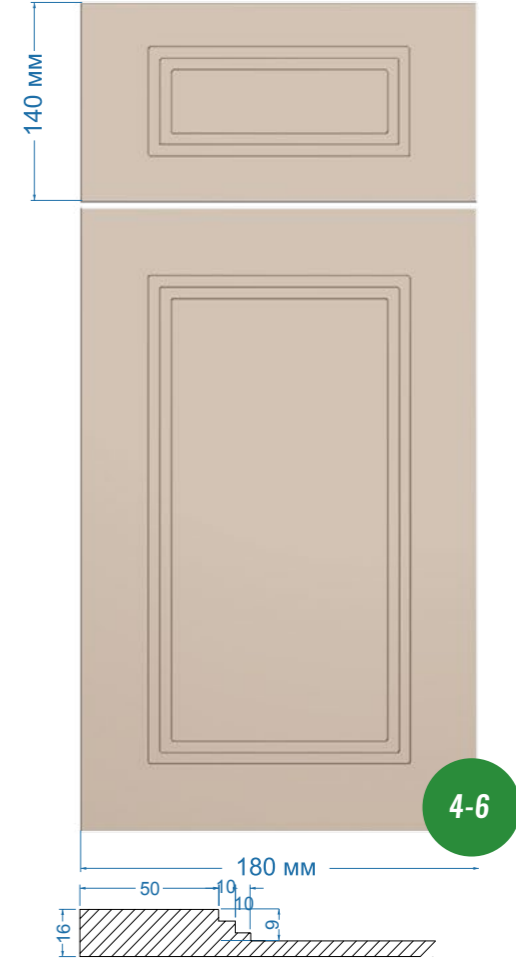
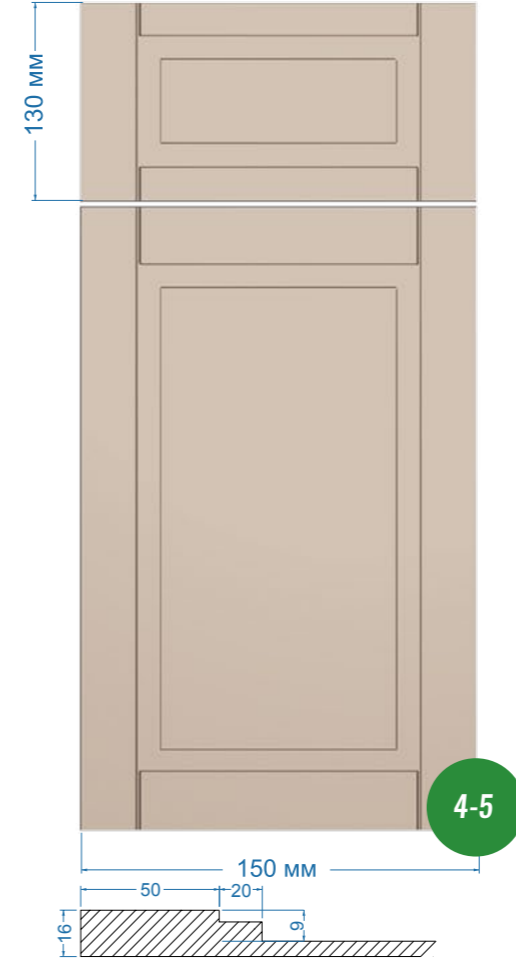
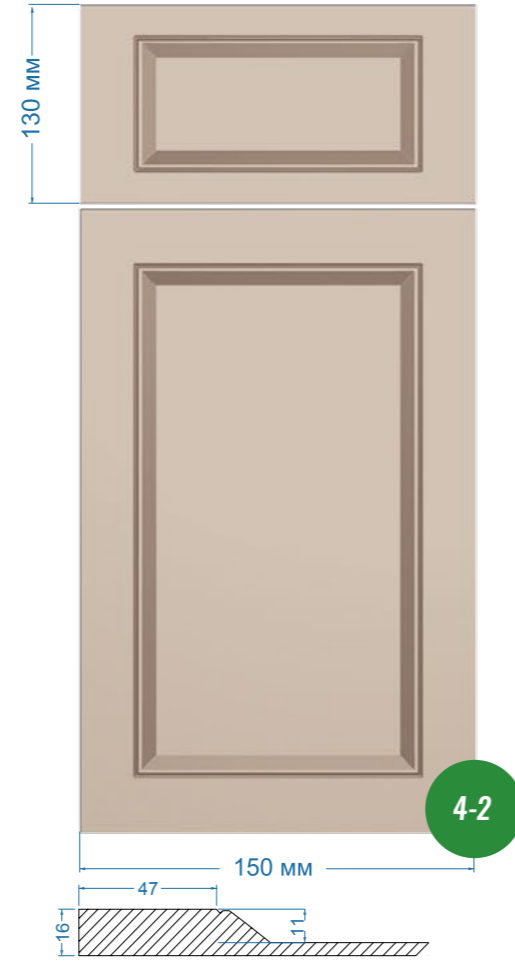

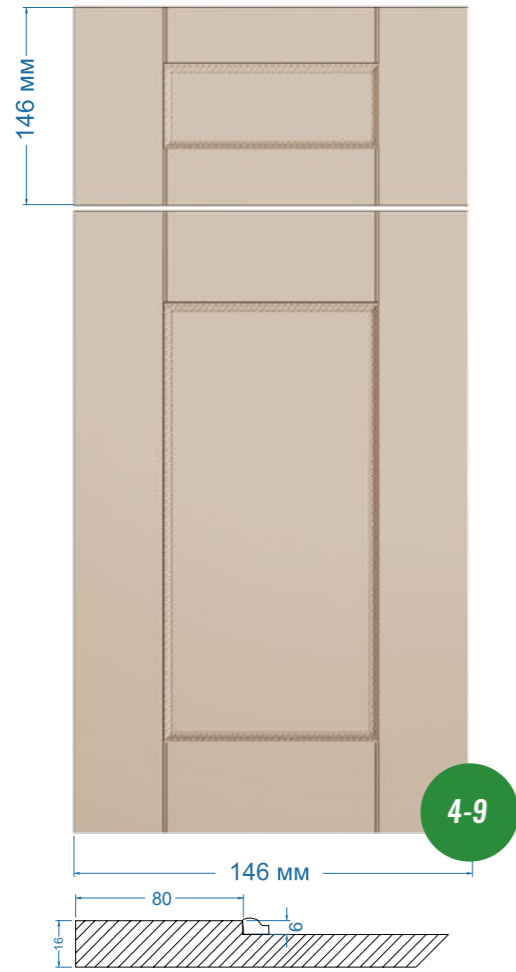

4-9



4-10



4-13



4-14



4-11



4-12



4-15

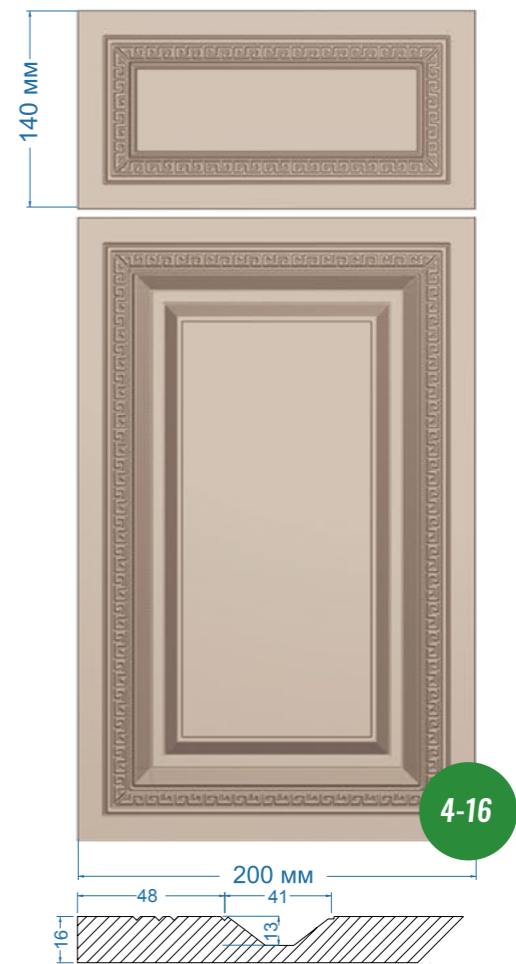

4-16

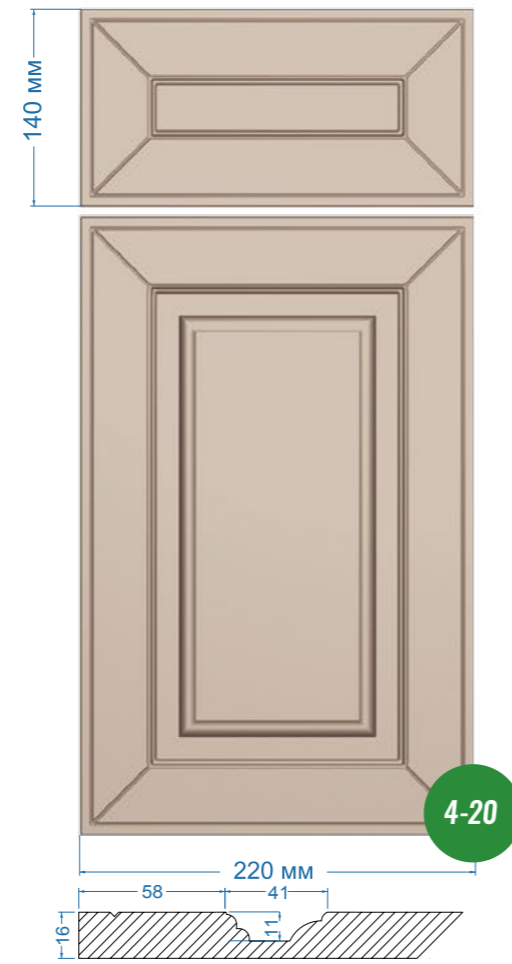



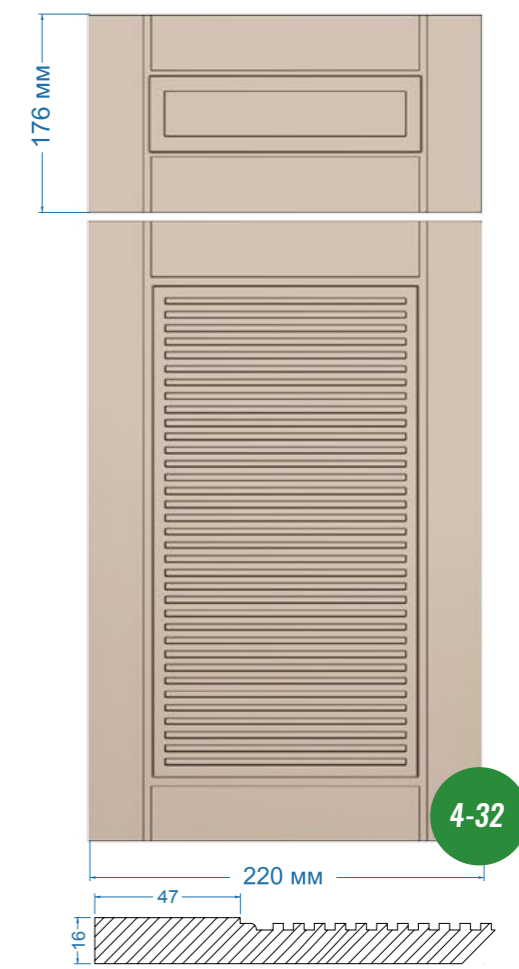
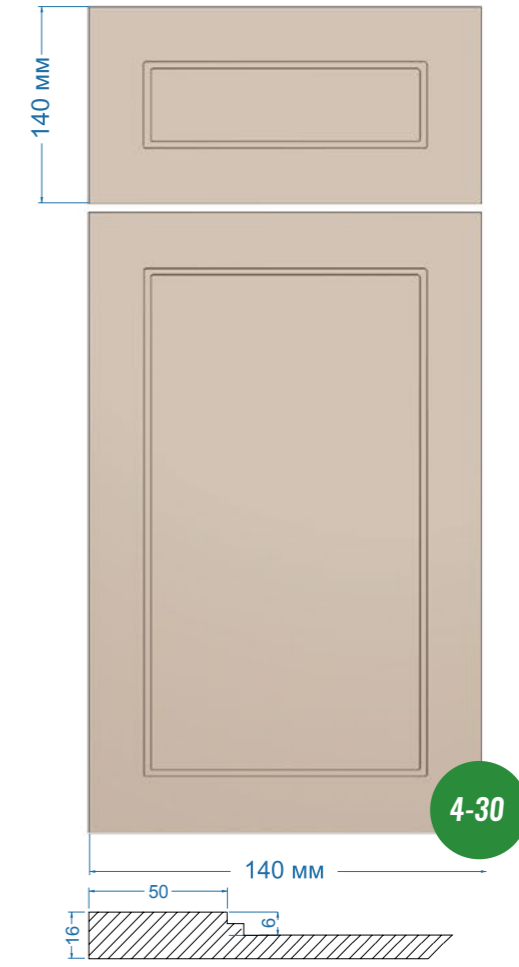
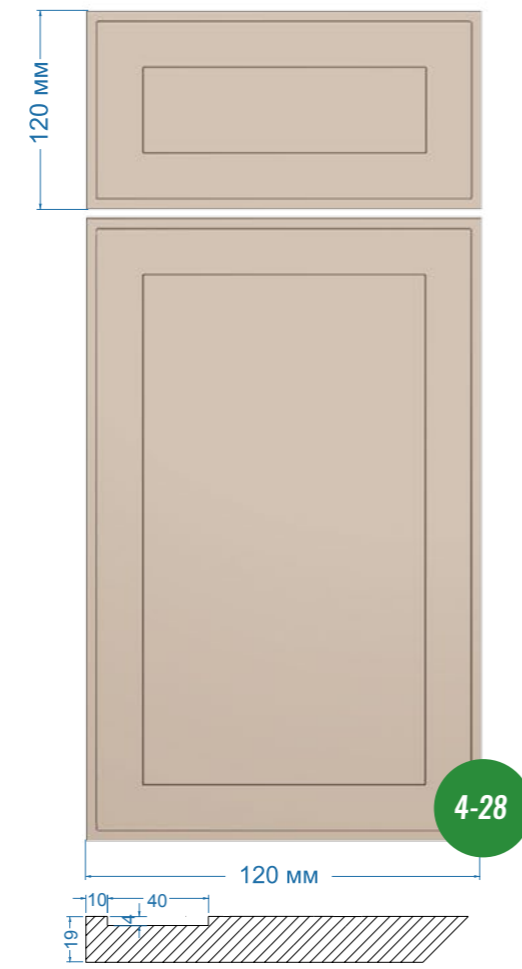
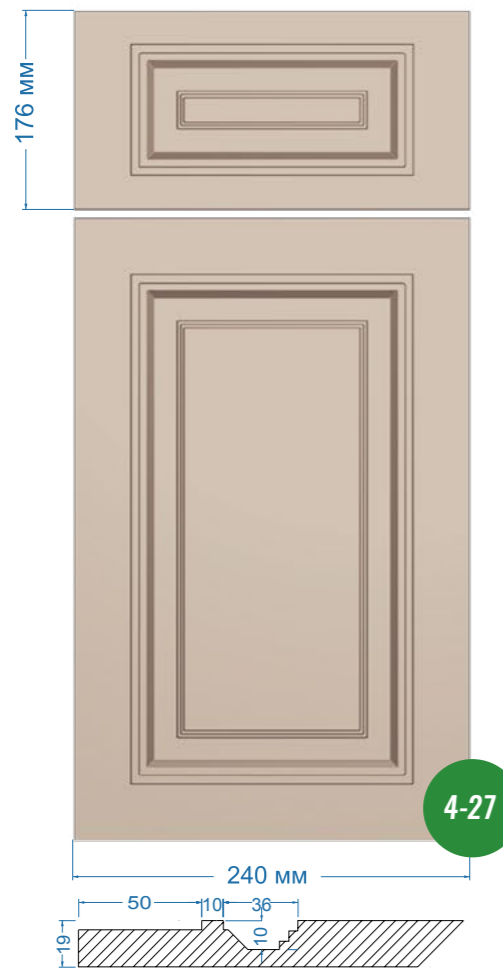
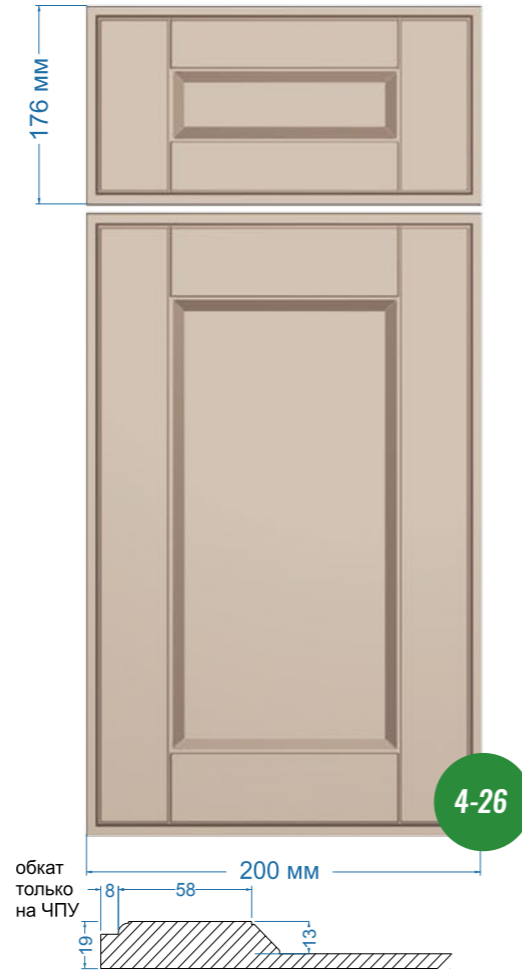

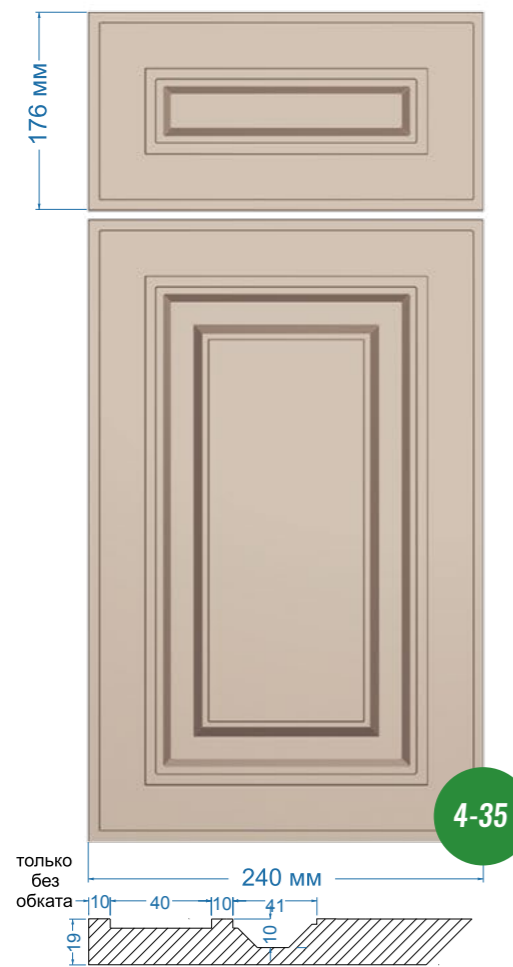
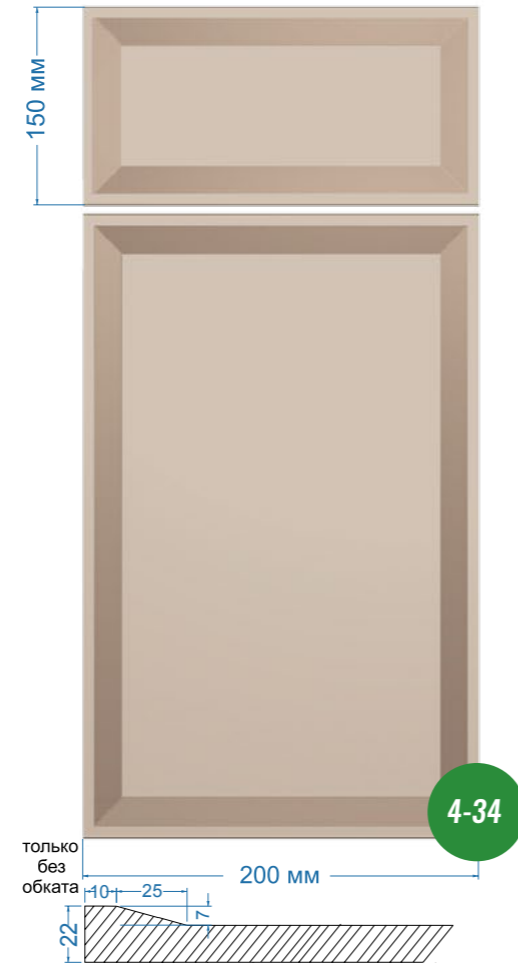
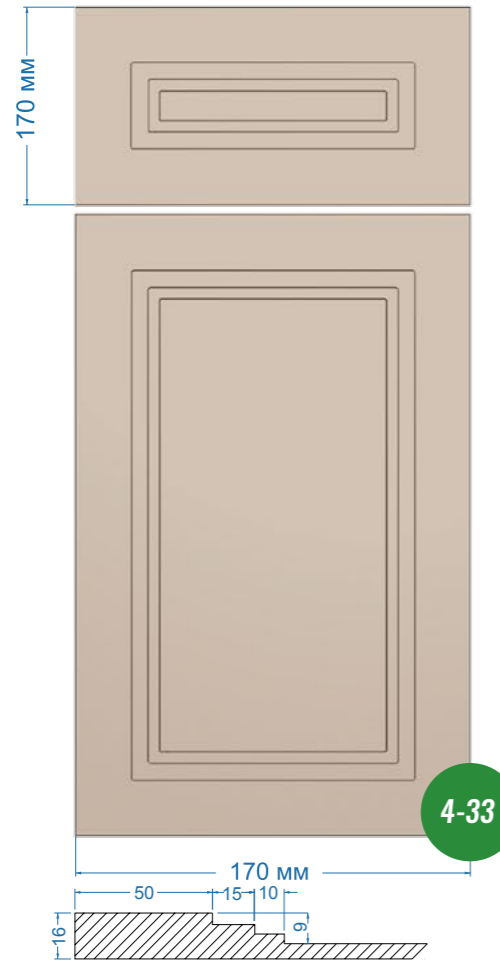

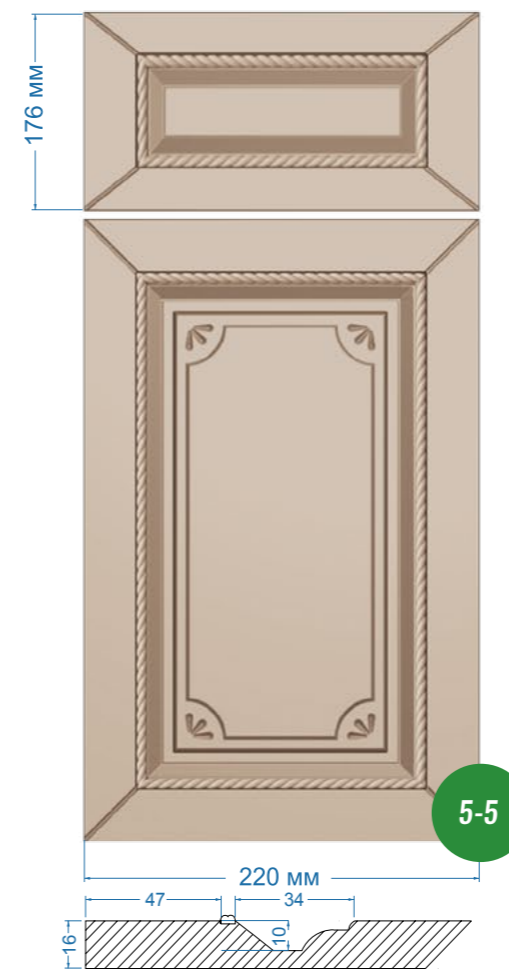



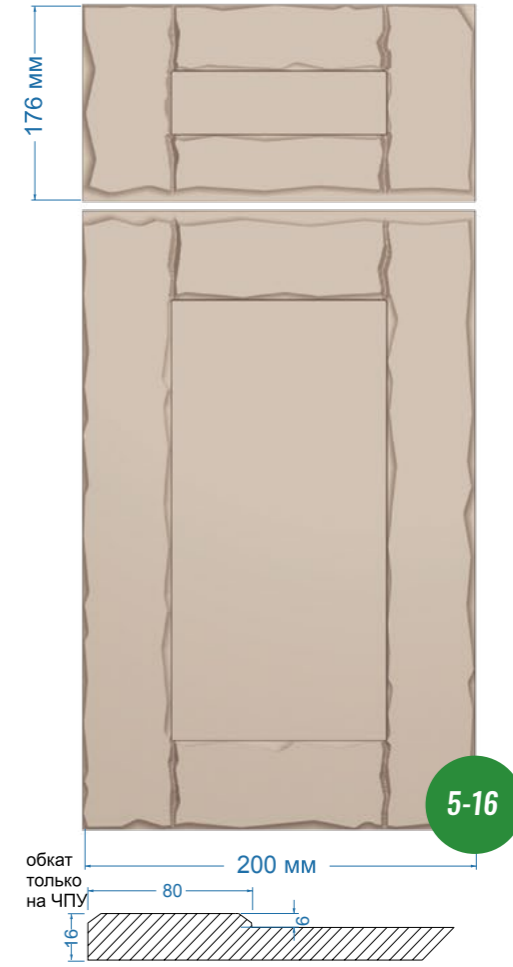
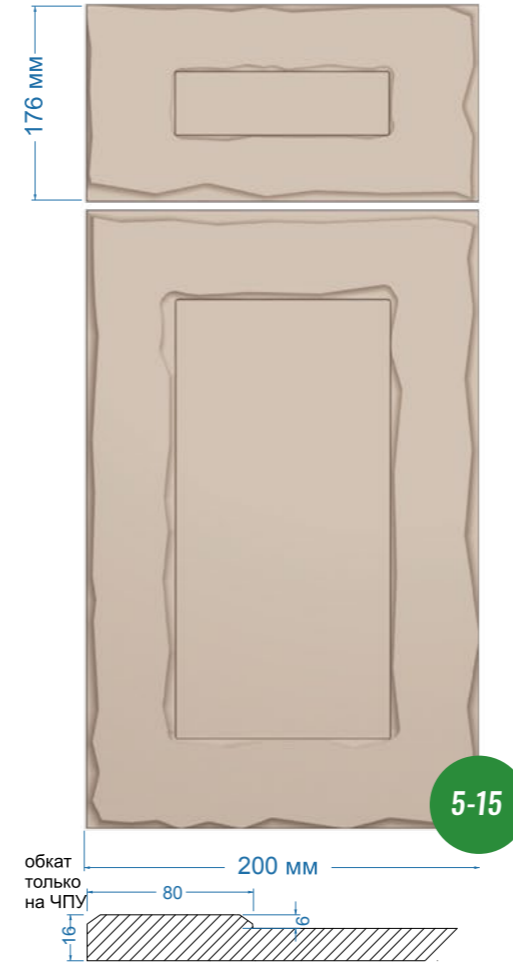
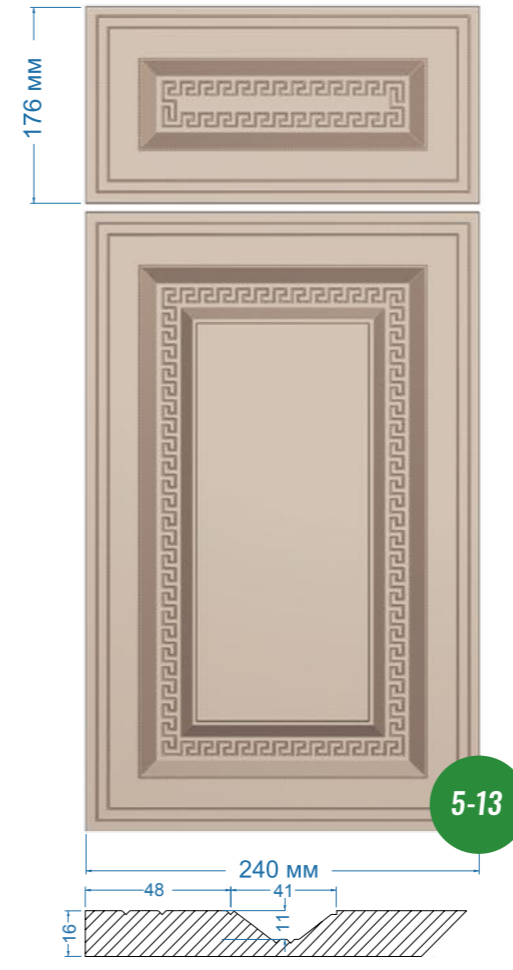

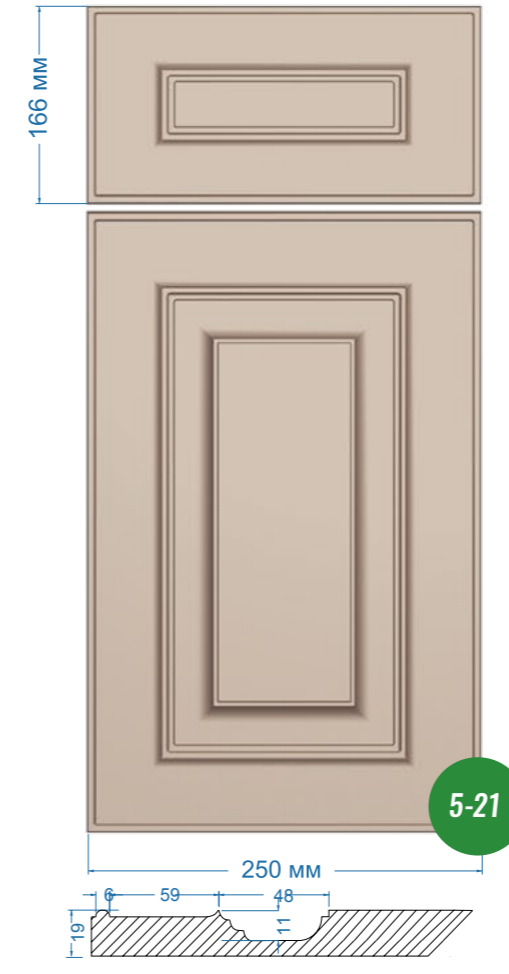
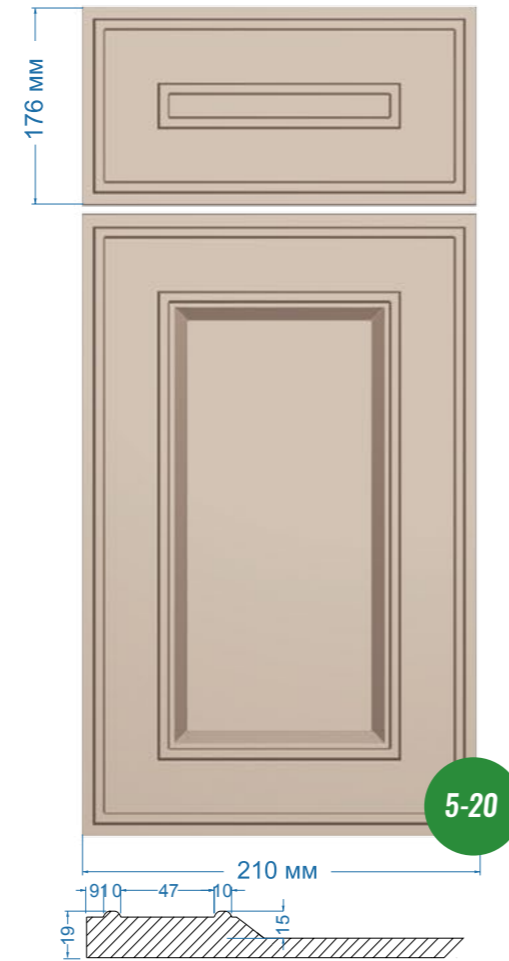
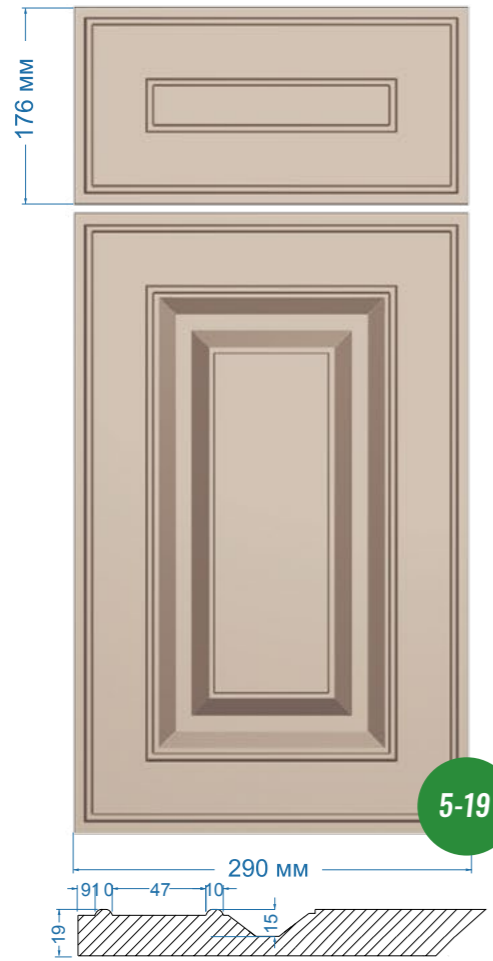
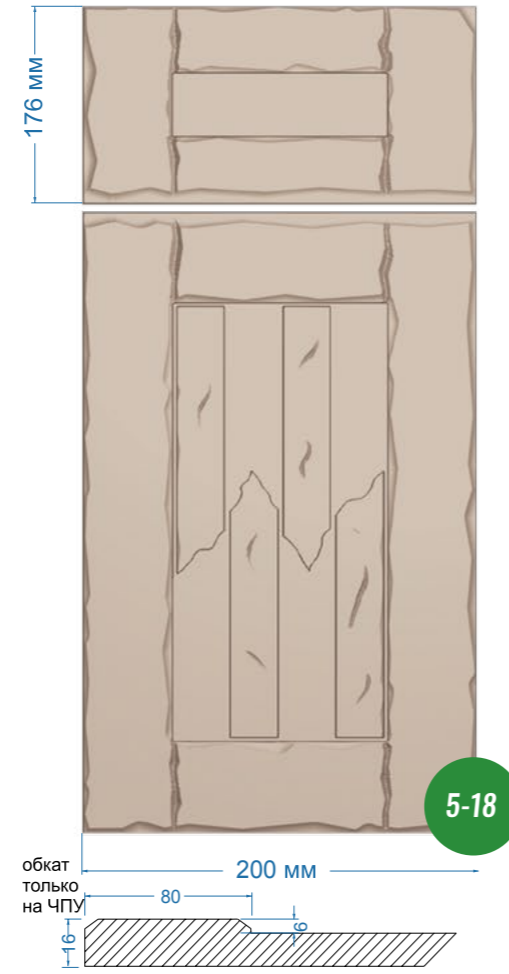
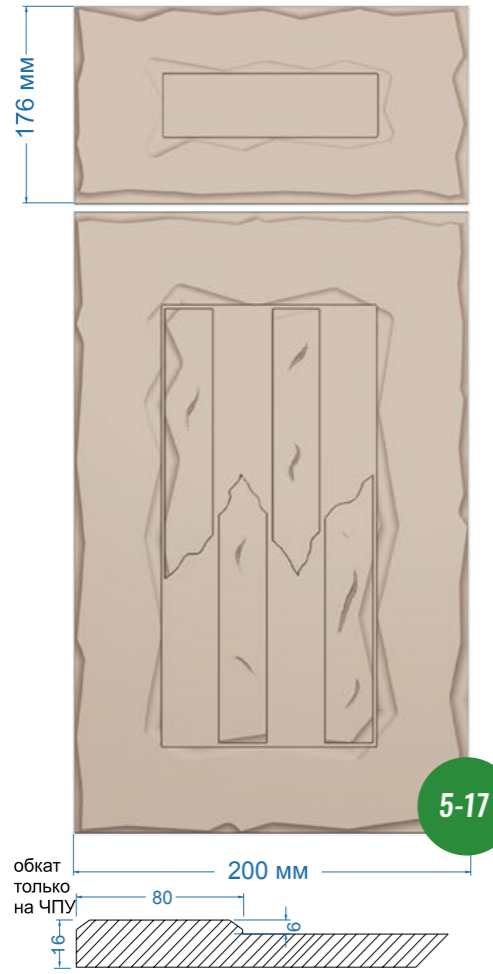



5-25



5-26



5-27



5-28



5-29

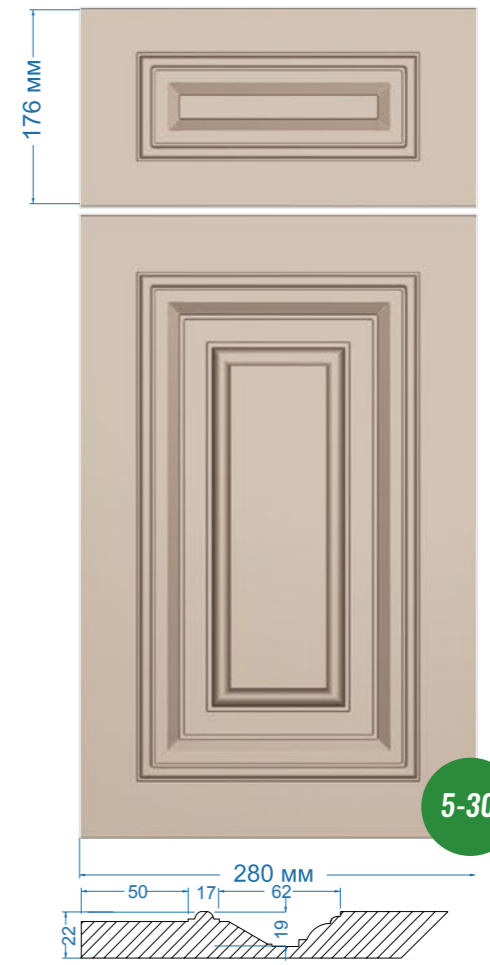

5-30



5-31



5-32



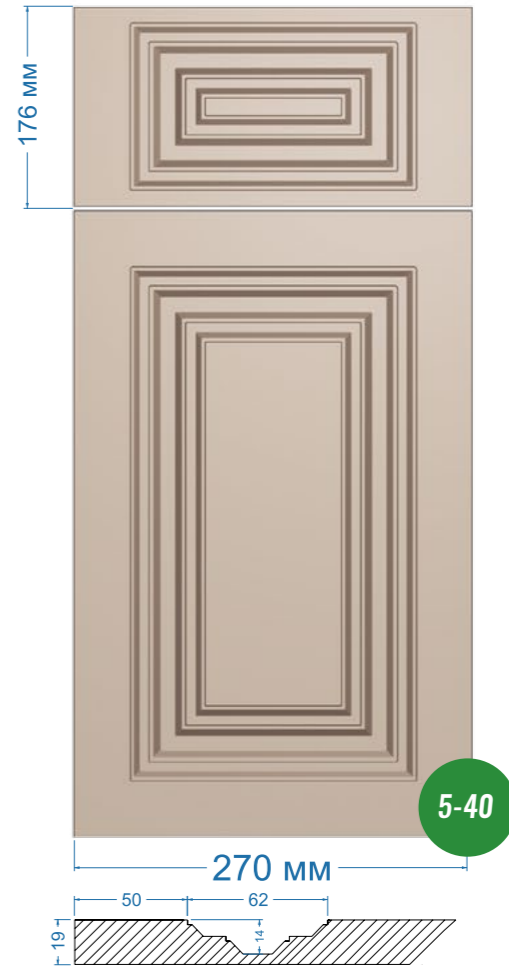
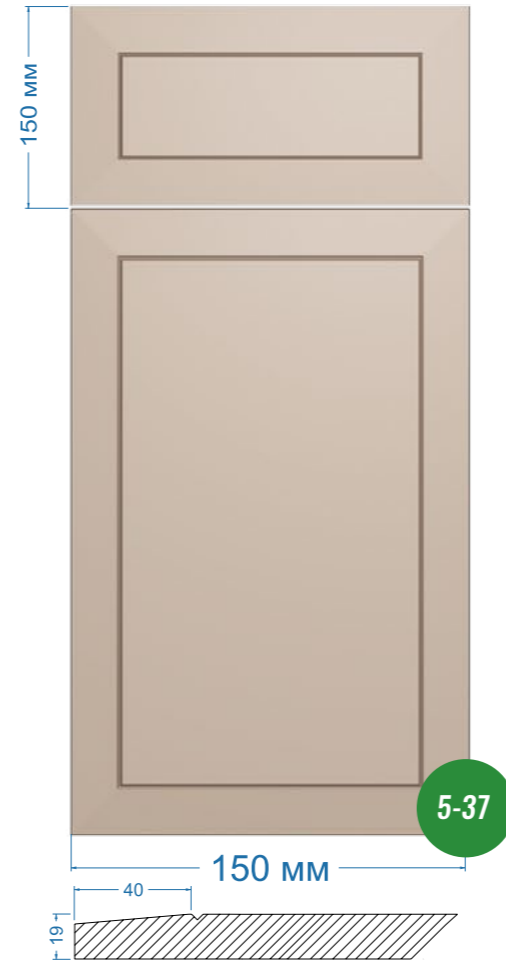
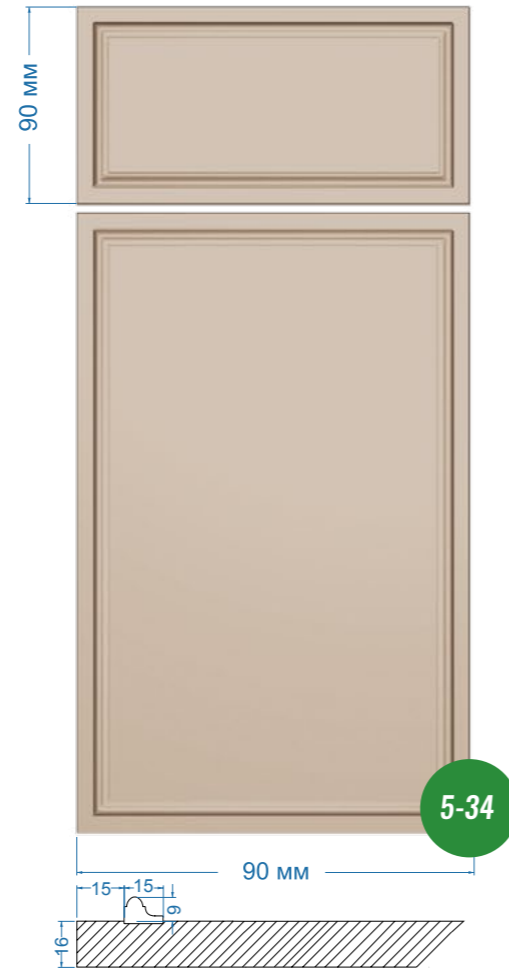
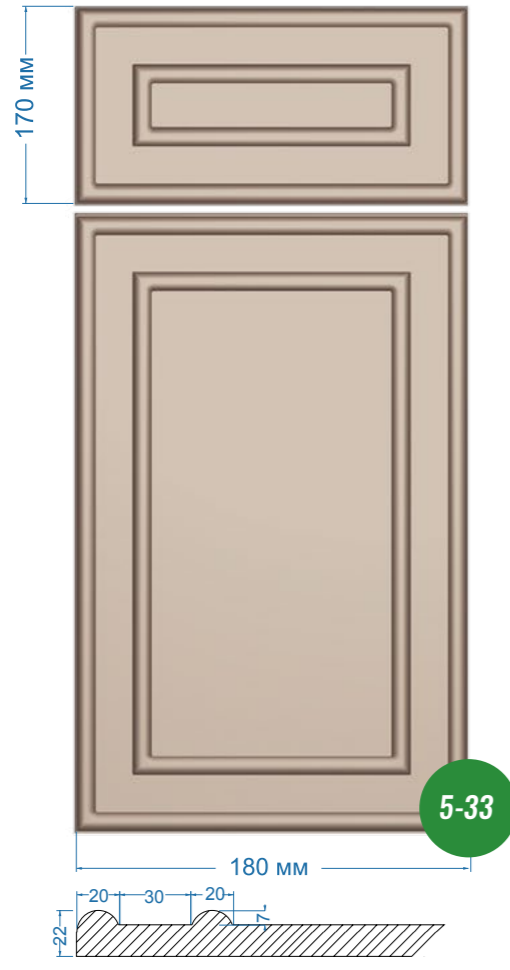







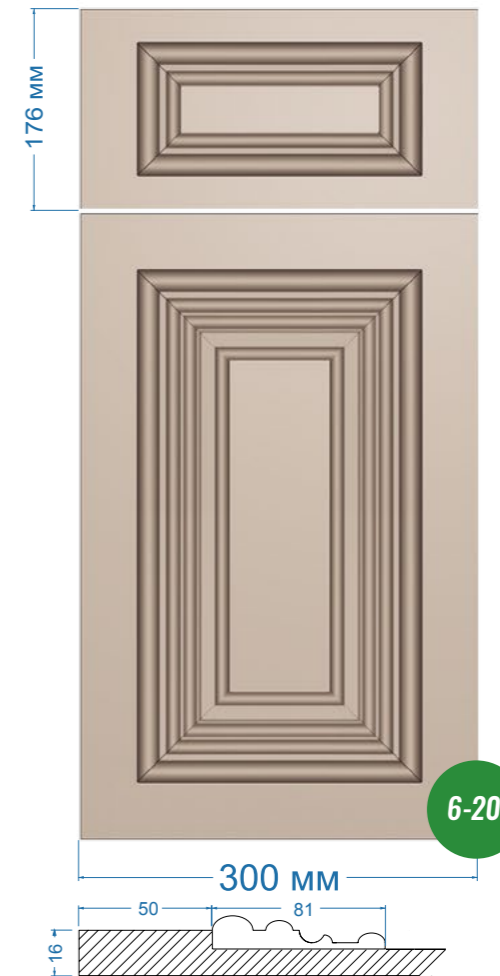

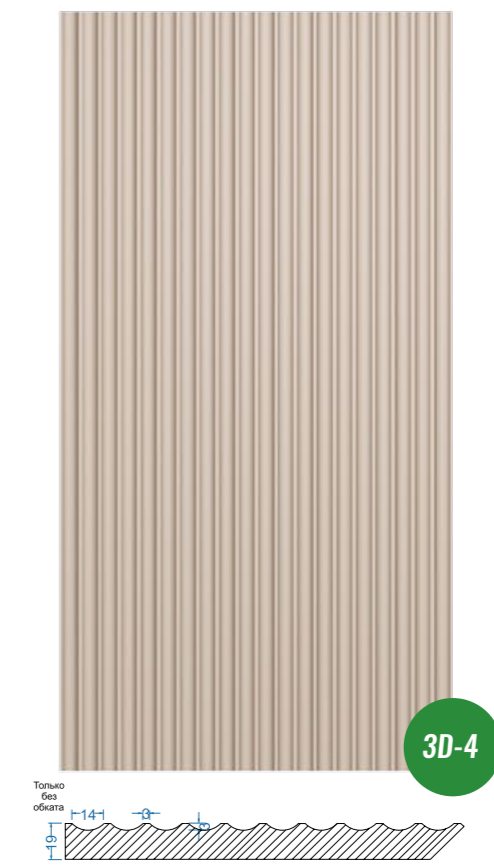
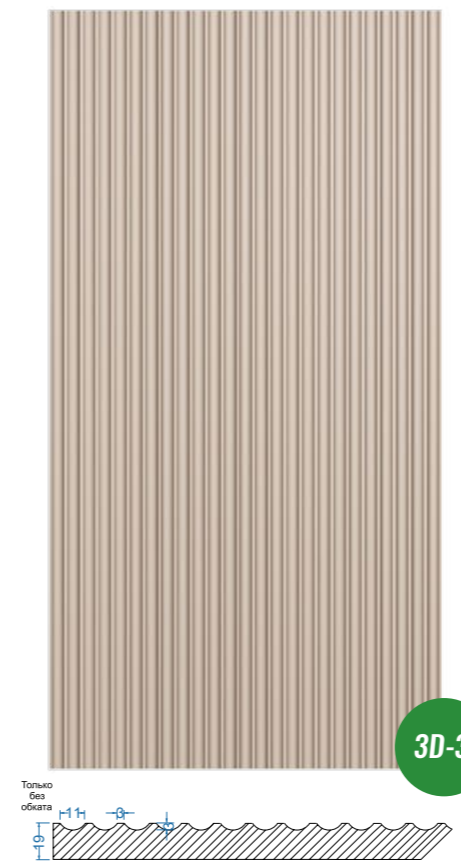
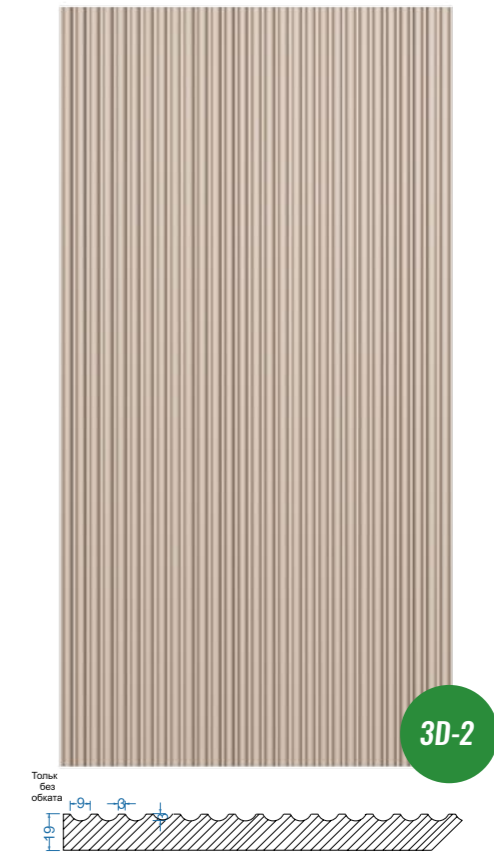
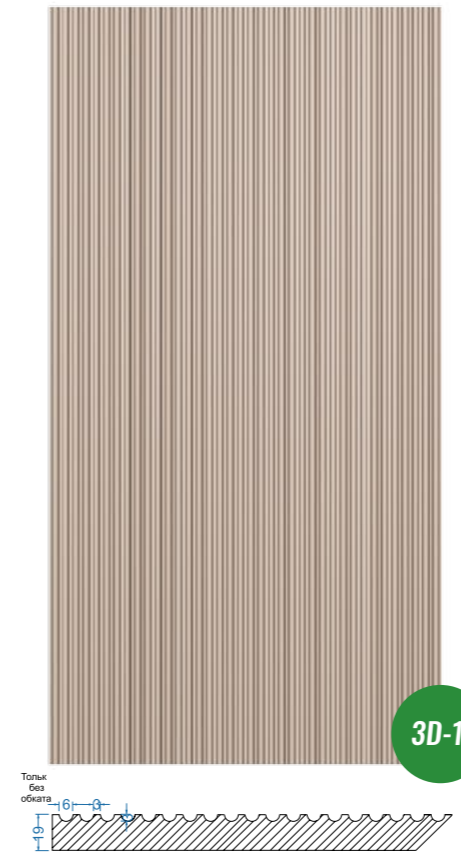
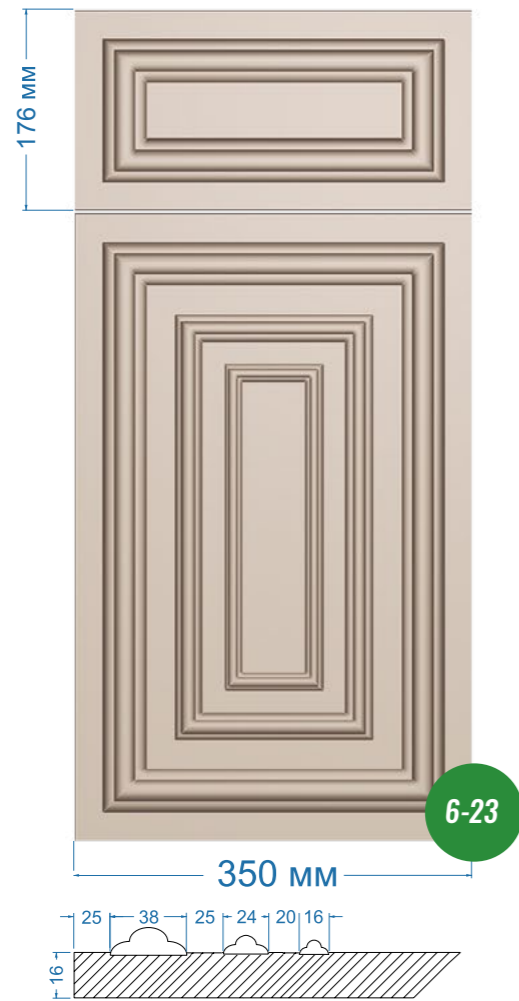
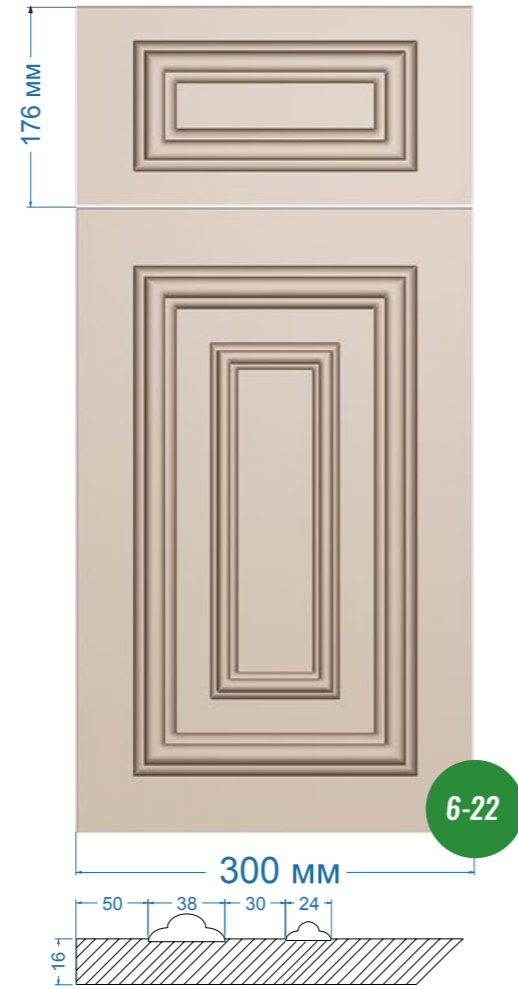



3D-5

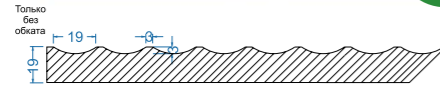

3D-6

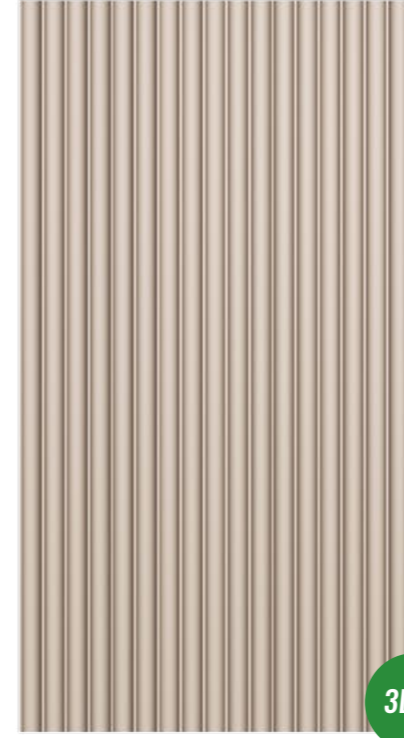
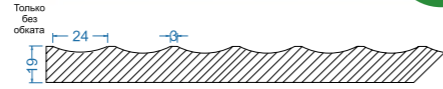

3D-9

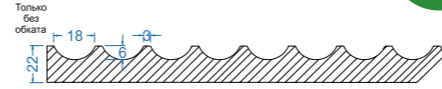

3D-10

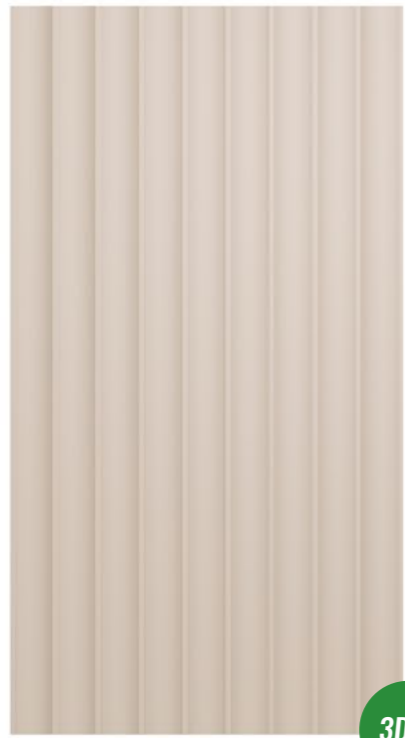
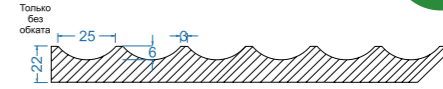

3D-7

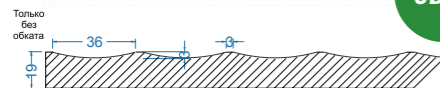

3D-8

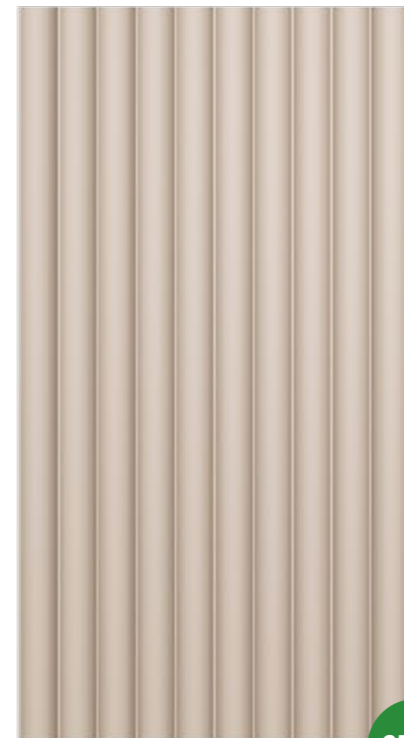

3D-11

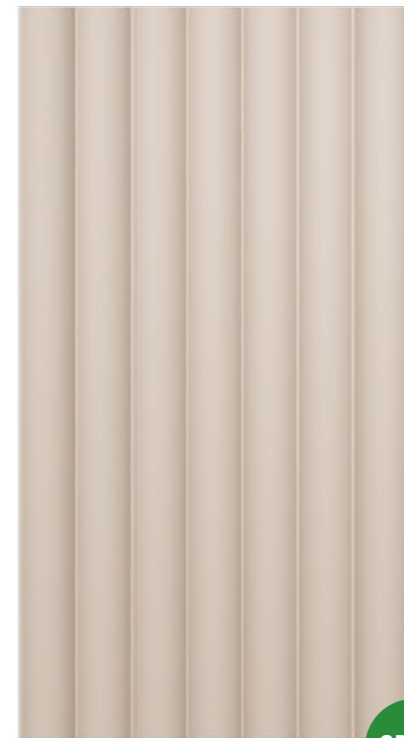
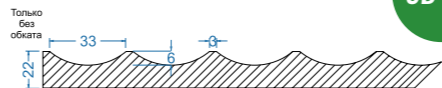

3D-12

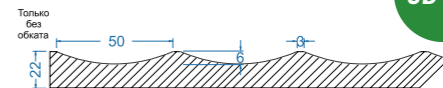



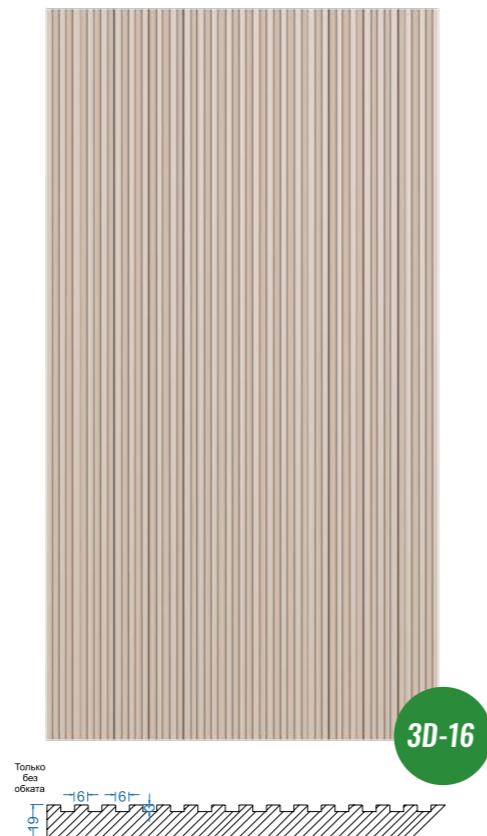
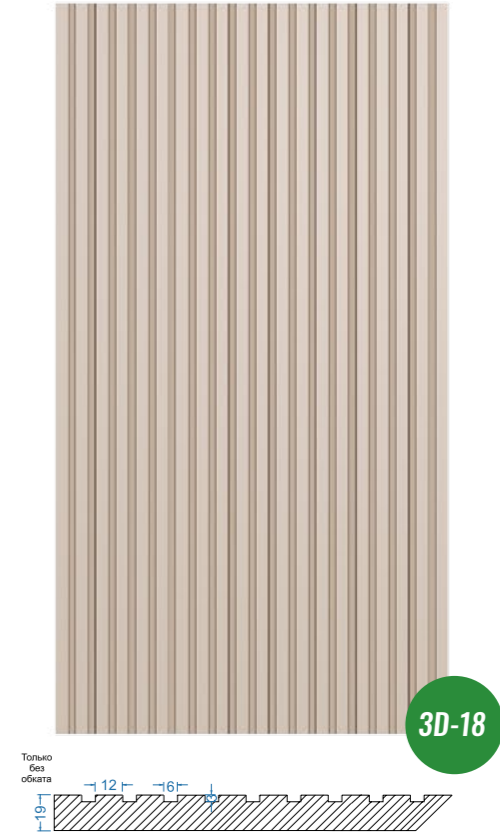
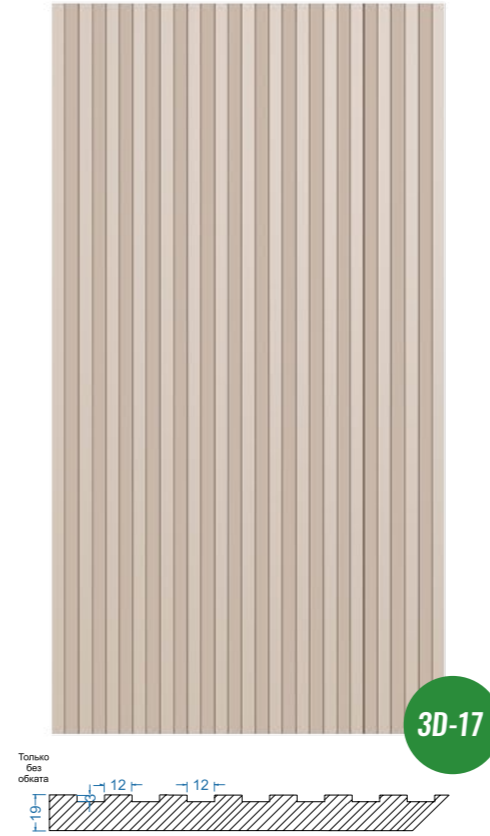
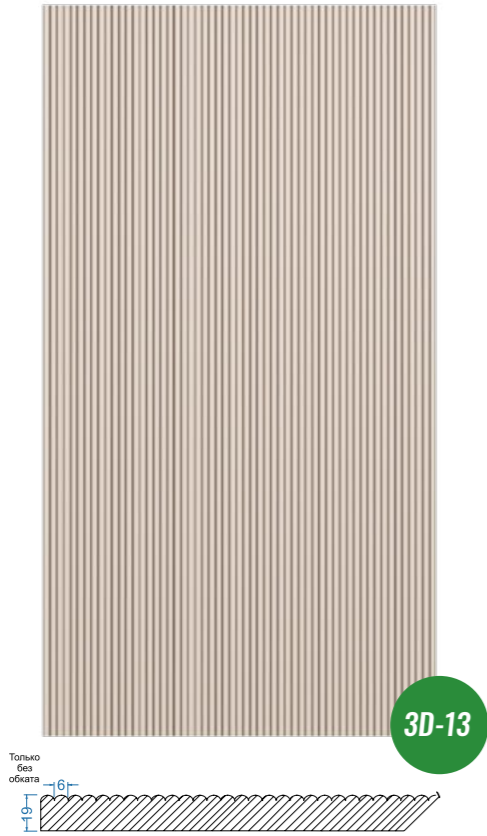



3D-21

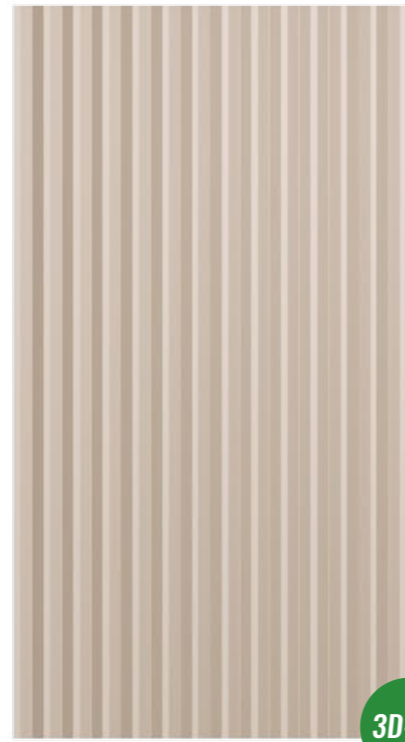

3D-22

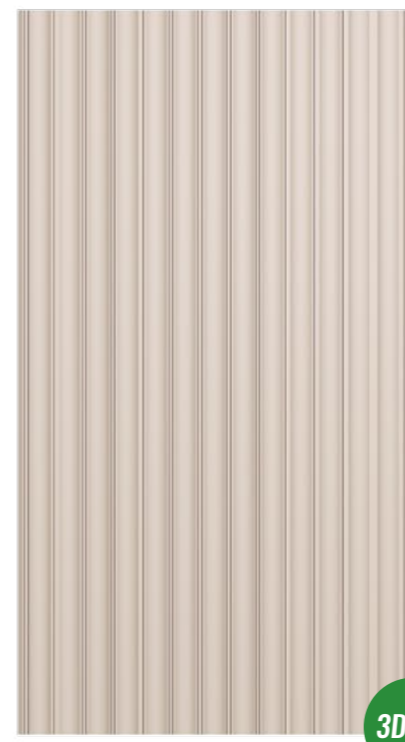
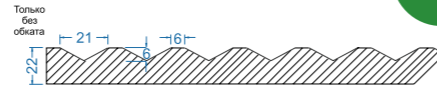

3D-25

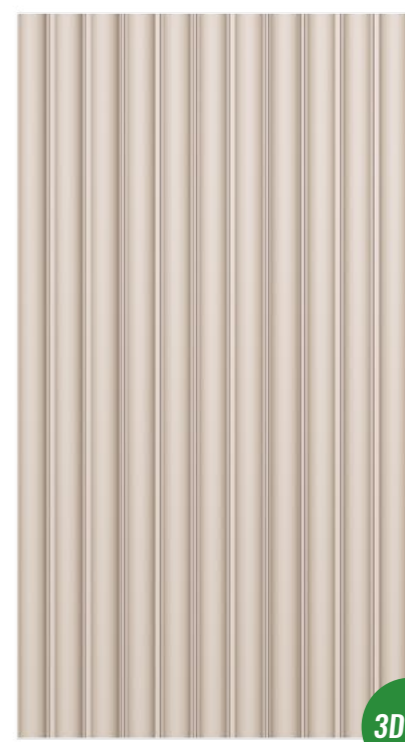
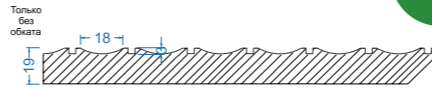

3D-26

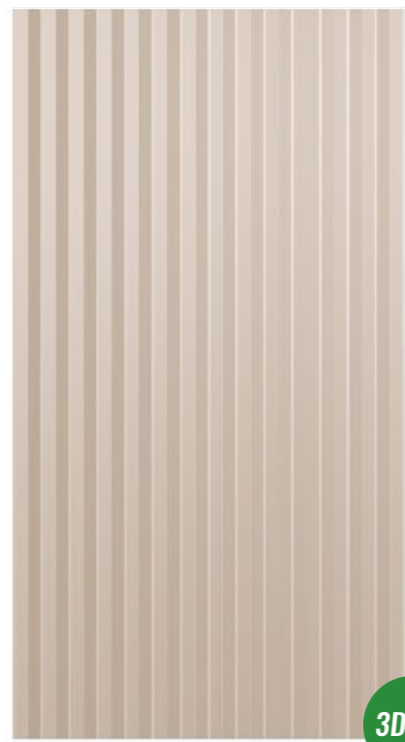
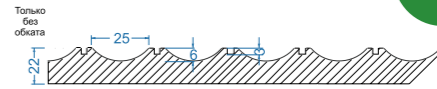

3D-23

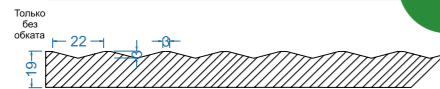

3D-24

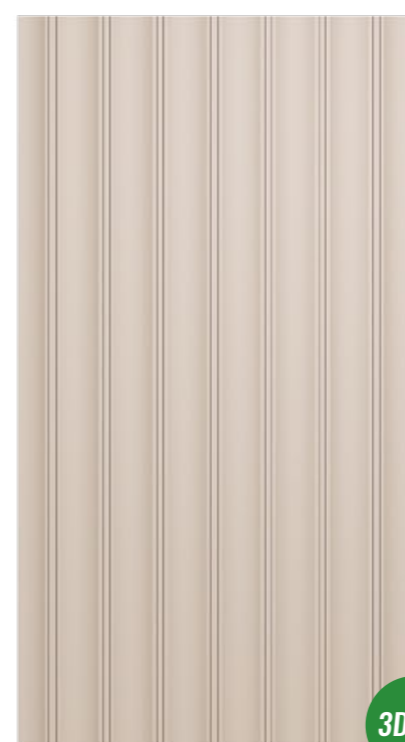
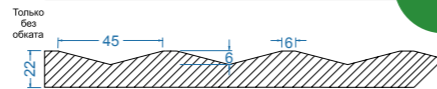

3D-27

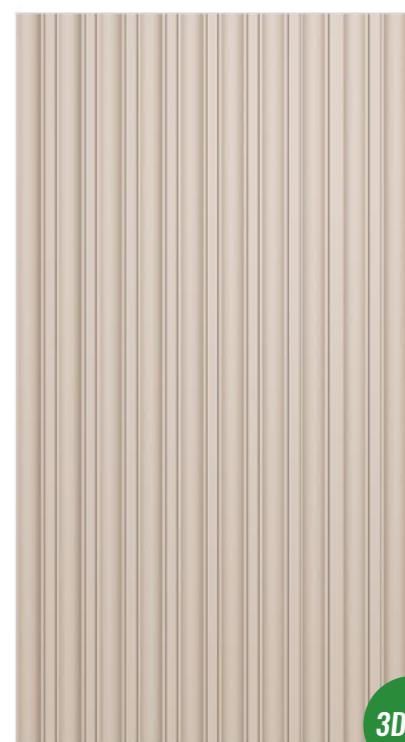

3D-28

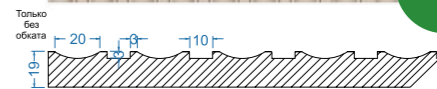



3D-29

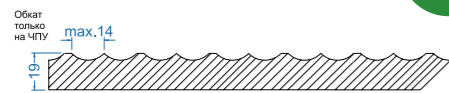

3D-30

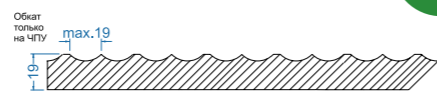

3D-33

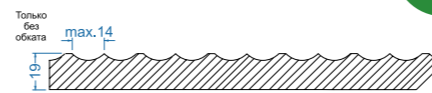

3D-34

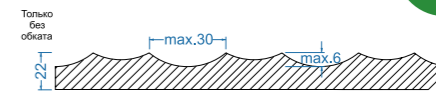

3D-31

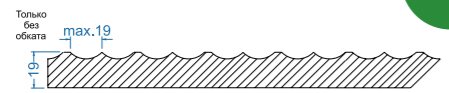

3D-32

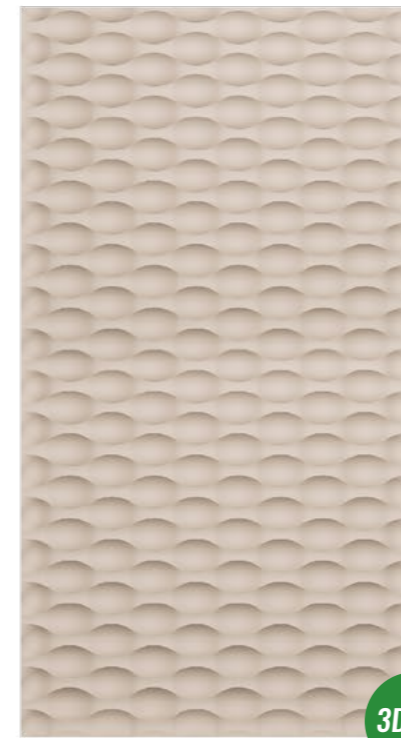
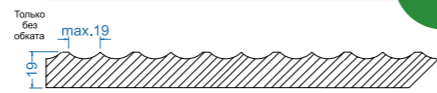

3D-35

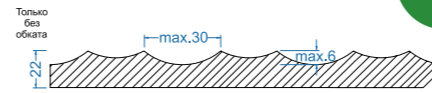

3D-36

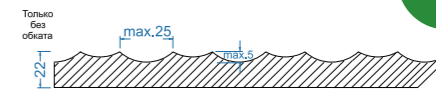



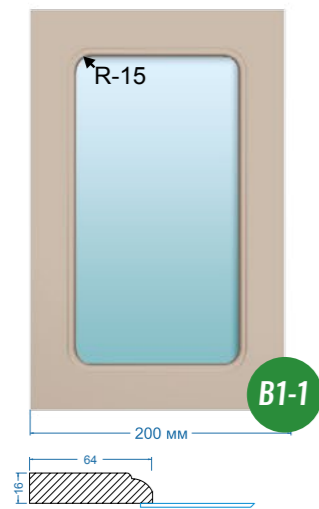

**B1-1**

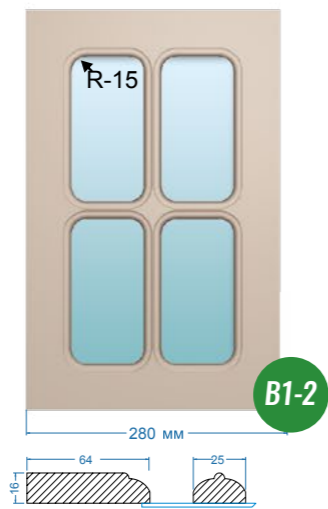

**B1-2**

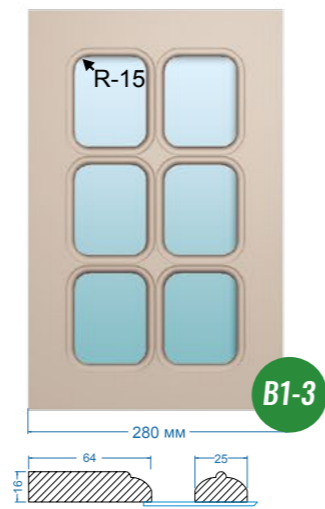

**B1-3**



**B1-4**



**B1-5**



**B1-6**



**B3-1**



**B3-2**

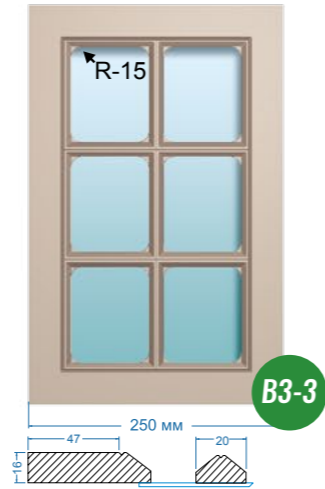

**B3-3**



**B3-4**



**B3-5**

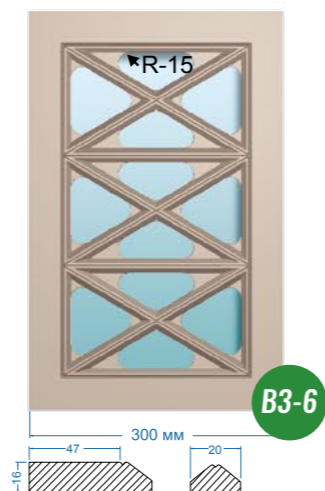

**B3-6**



**BФ-1**

- возможно изготовления глухой ВФ
- только с выборкой 10\*10 мм, с прокрасом белой краской
- в комплекте штапики пластиковые, белого цвета 6\*10, под размер витрины
- возможно изготовления дугового фасада, только без выборки, перекрестия при этом утолщаются до 20 мм

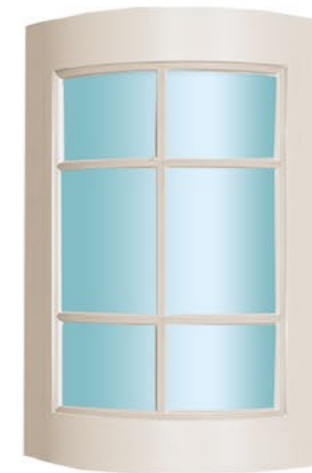

**BФ-1**

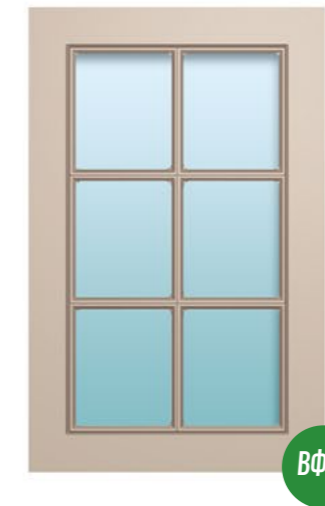

**BФ-2**

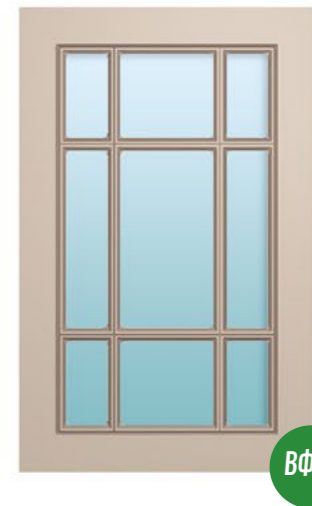

**BФ-3**



**BФ-4**



**BФ-5**



**BФ-6**



ВФ-7



ВФ-8



ВФ-9



ВФ-16

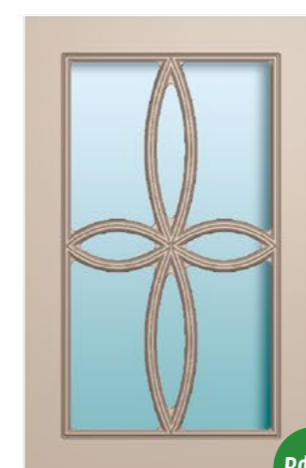

ВФ-17

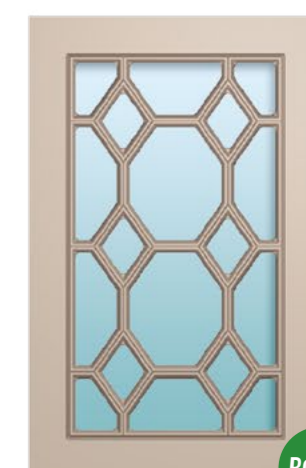

ВФ-18



ВФ-10

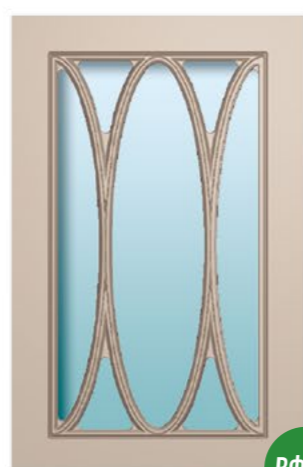

ВФ-11

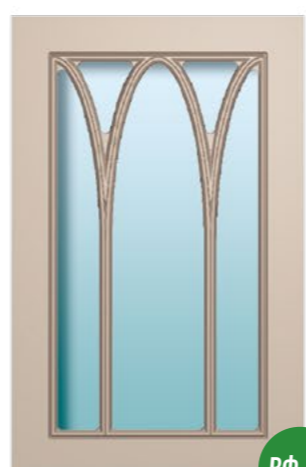

ВФ-12

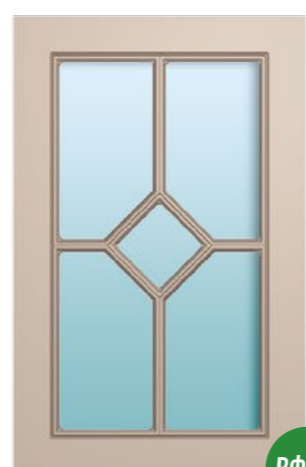

ВФ-19

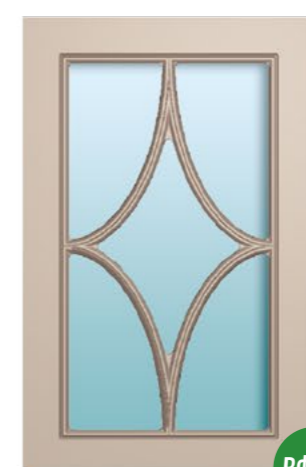

ВФ-20

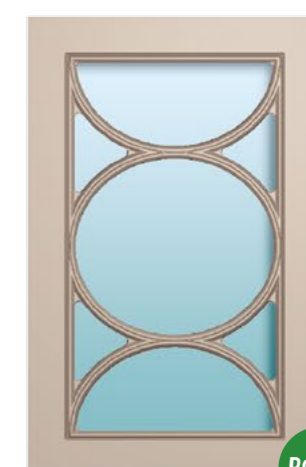

ВФ-21



ВФ-13

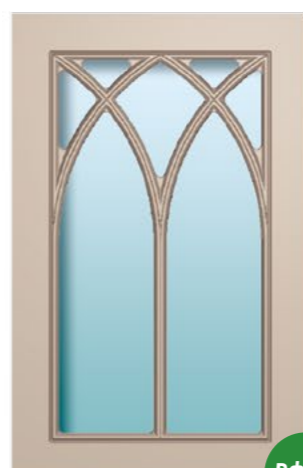

ВФ-14

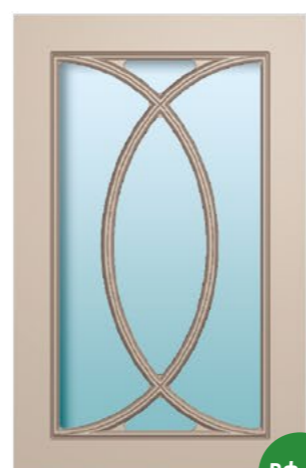

ВФ-15



ВФ-22

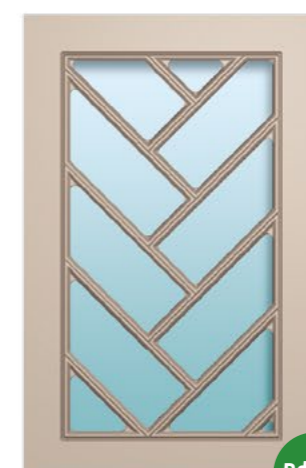

ВФ-23

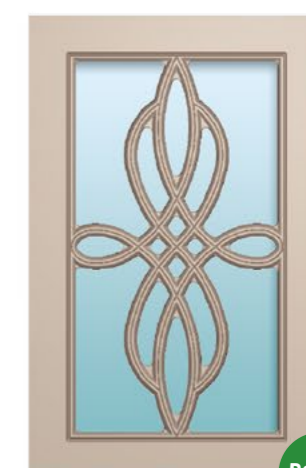

ВФ-24





P-1



P-2



P-5

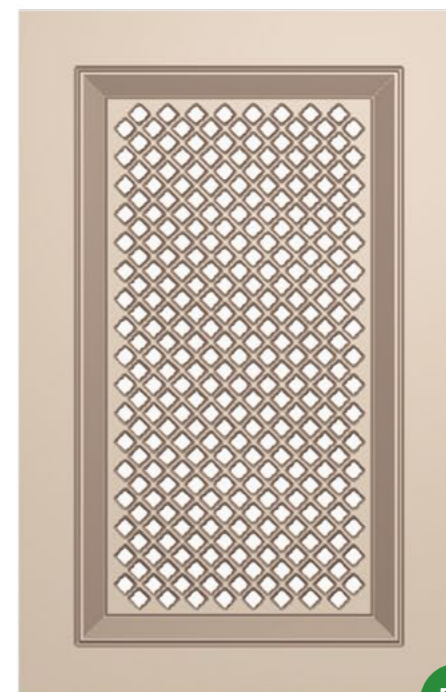

P-6



P-3



P-4



P-7

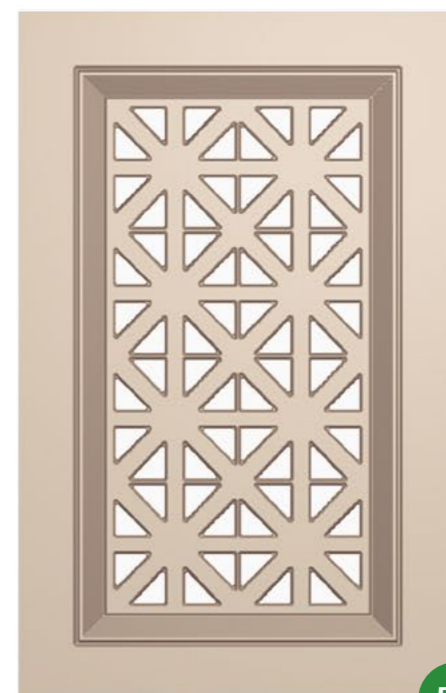

P-8





P-9

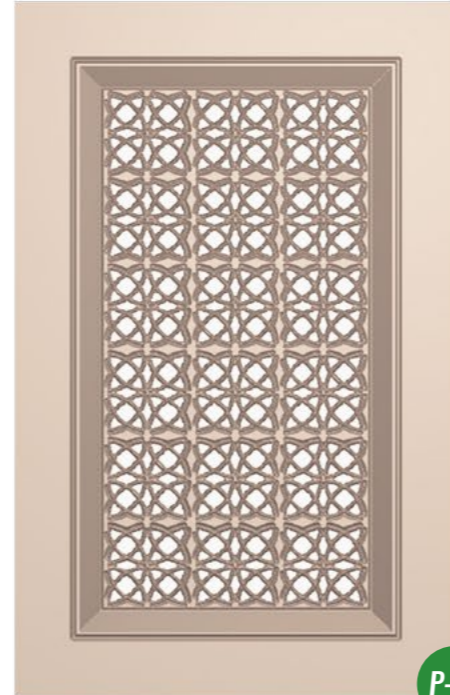

P-10



P-13



P-14



P-11



P-12

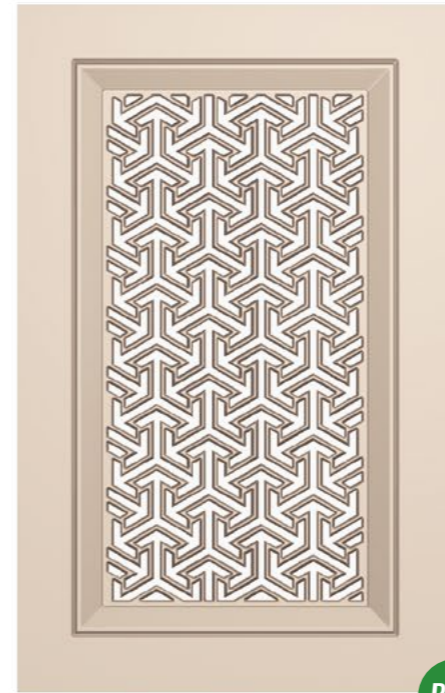

P-15

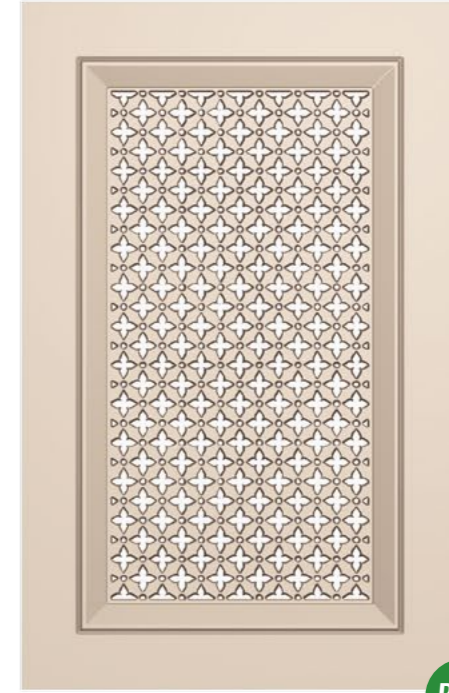

P-16



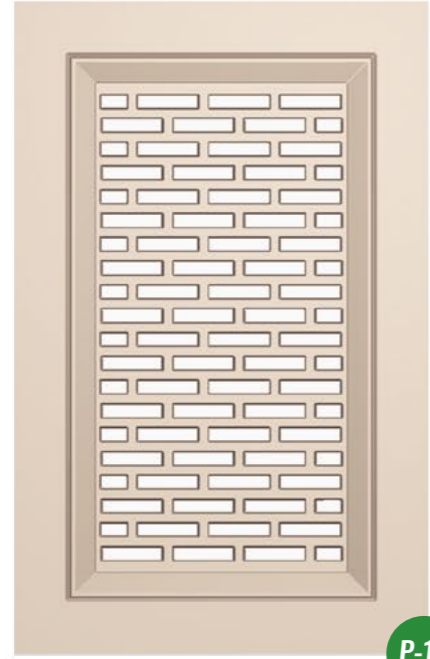

P-17

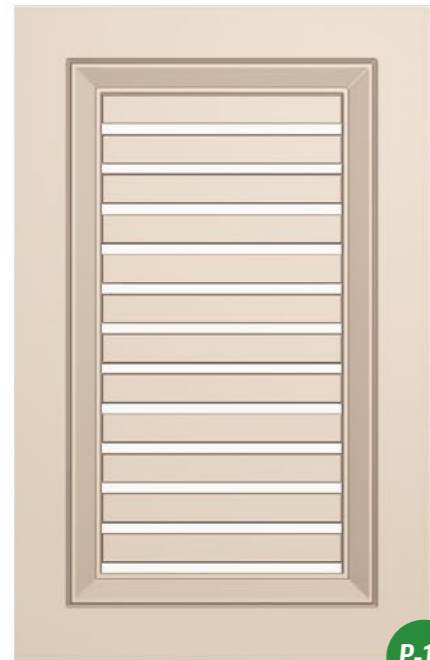

P-18



Ж-1

Жалюзи сборные

- делается на любых фасадах, кроме дуговых
- каждая рейка обгнута ПВХ или покрашена
- задняя сторона полностью ламинированная



Ж-2

Жалюзи фрезерованные,  
глухие, без отверстий, имитация

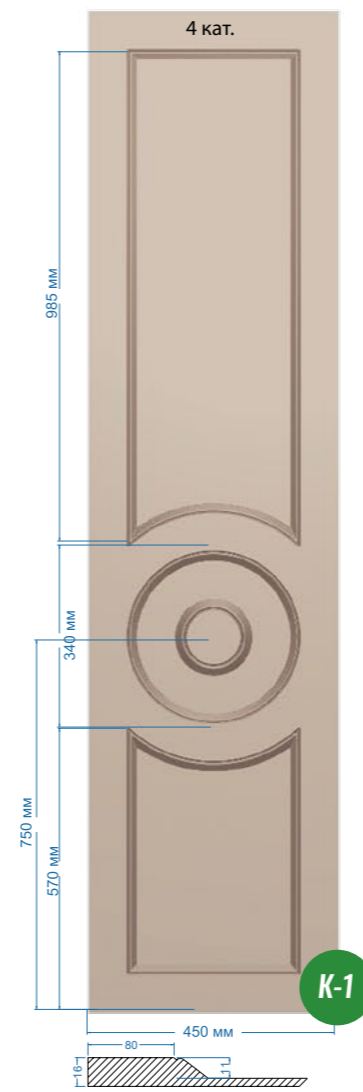

K-1

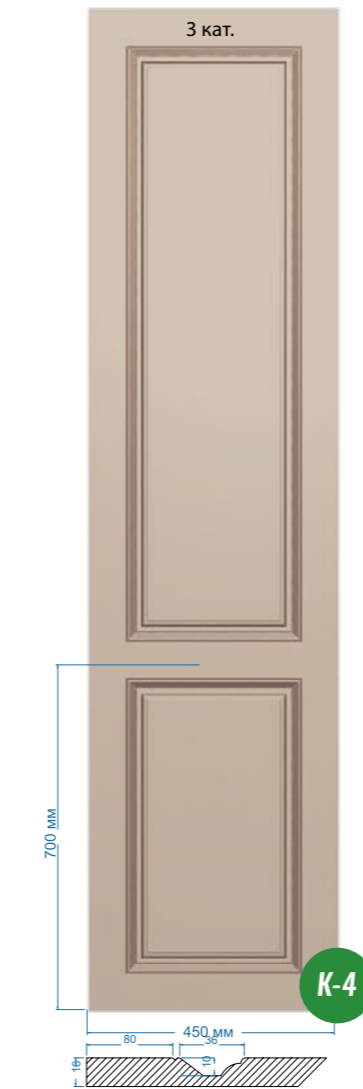

K-4

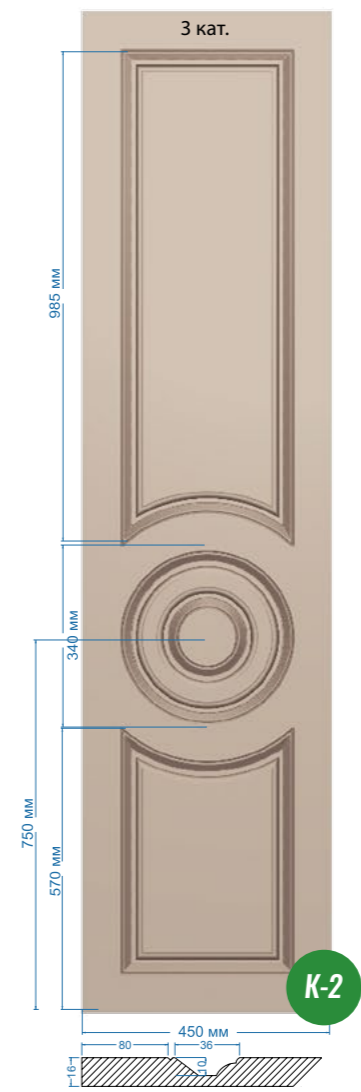

K-2

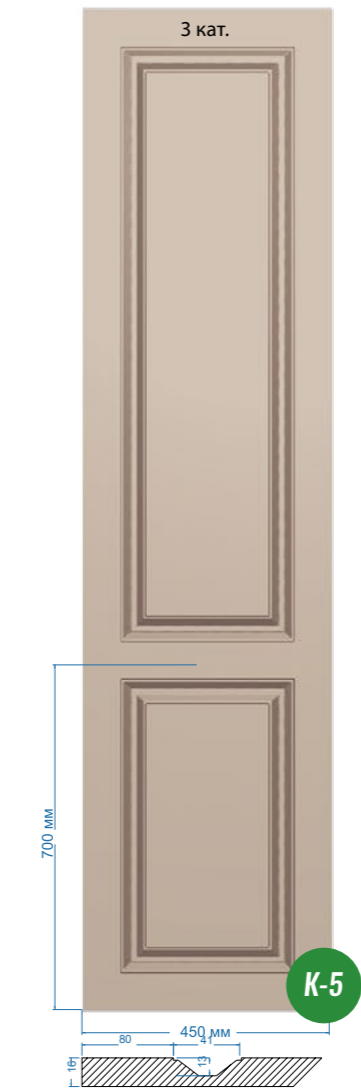

K-5

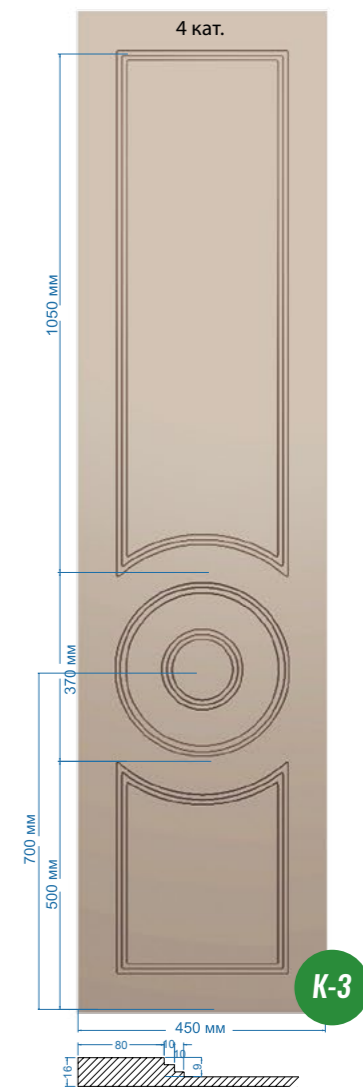

K-3

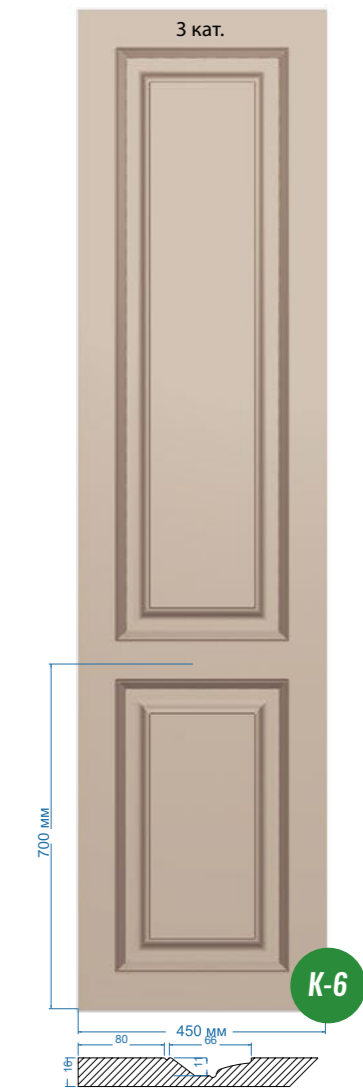

K-6

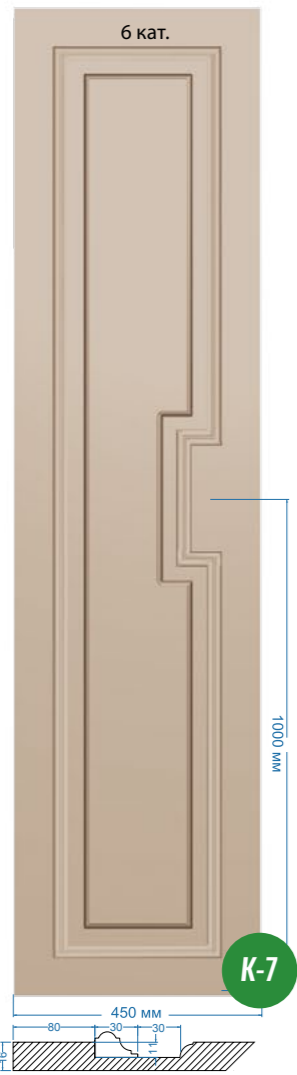

К-7

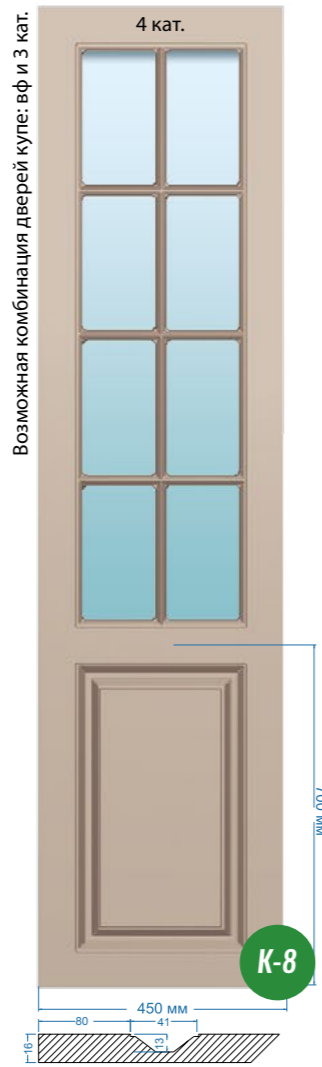

К-8

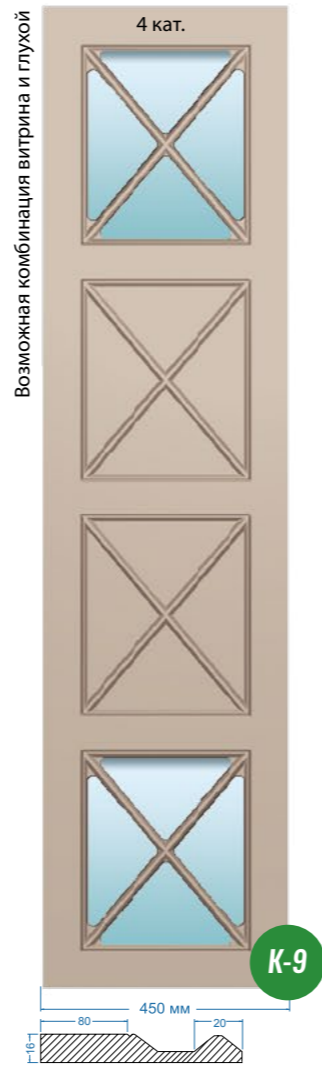

К-9

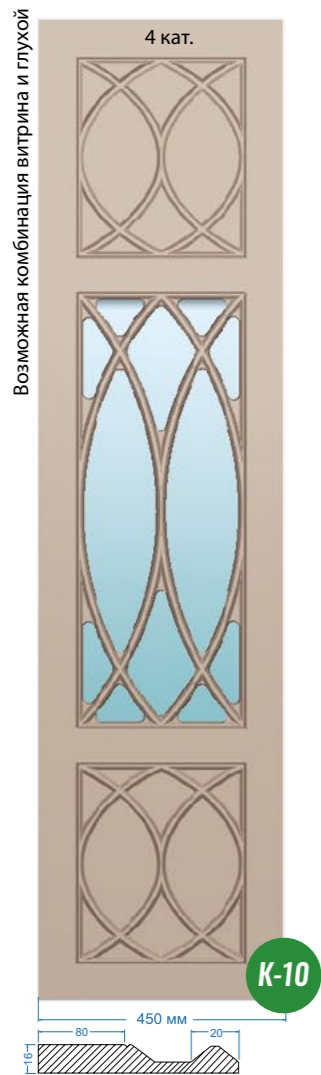

К-10



К-11

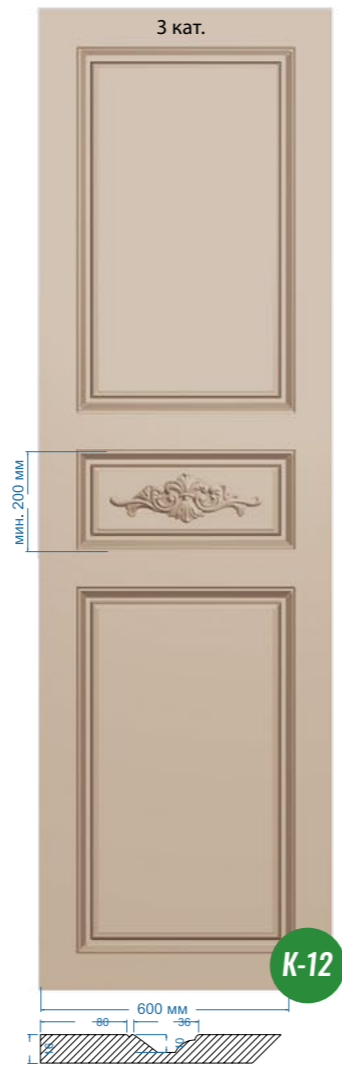

К-12

Возможная комбинация дверей купе: вф и 3 кат.

Возможная комбинация витрина и глухой

Возможная комбинация витрина и глухой

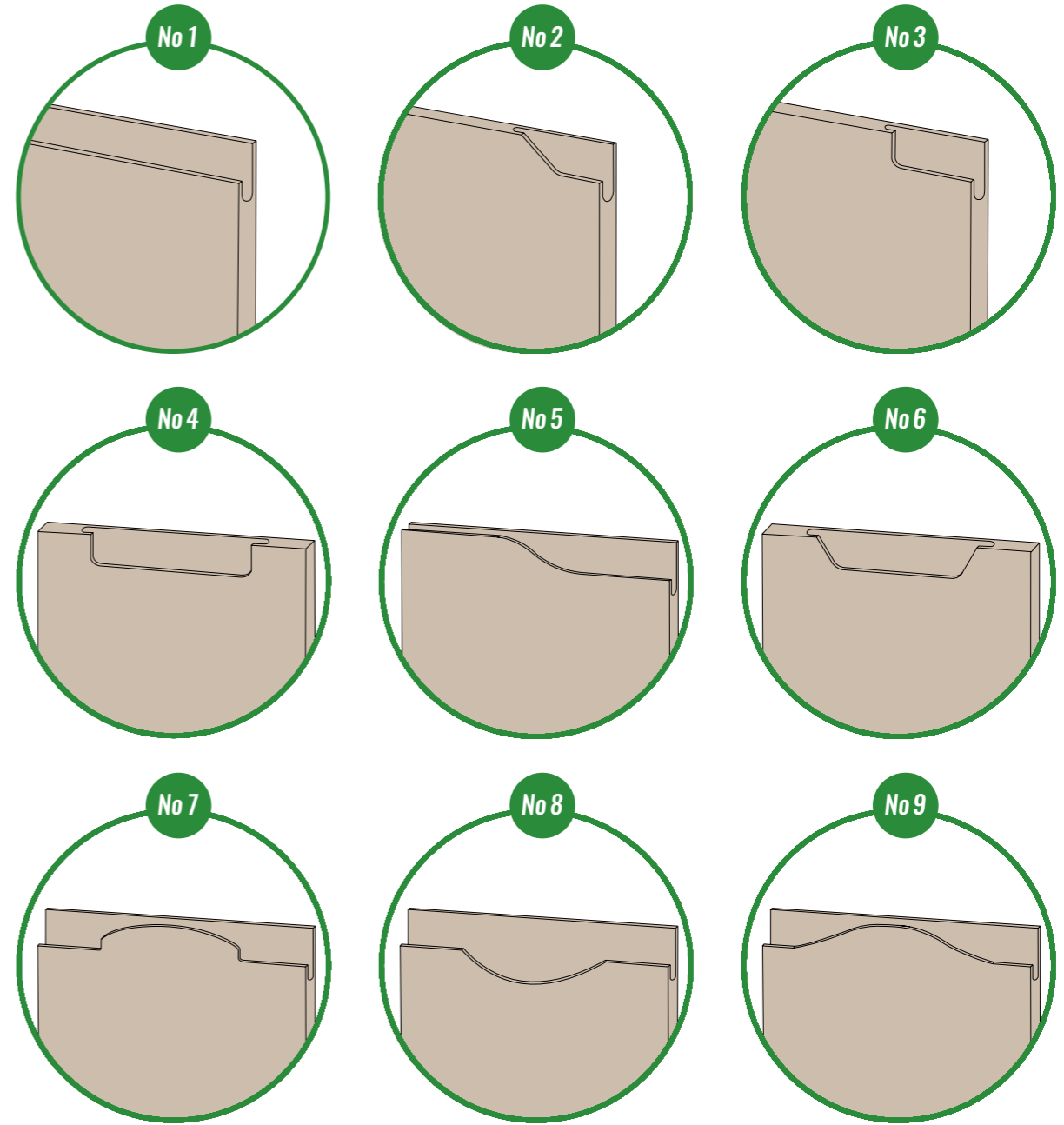

Профиль (сечение), толщина и возможное исполнение

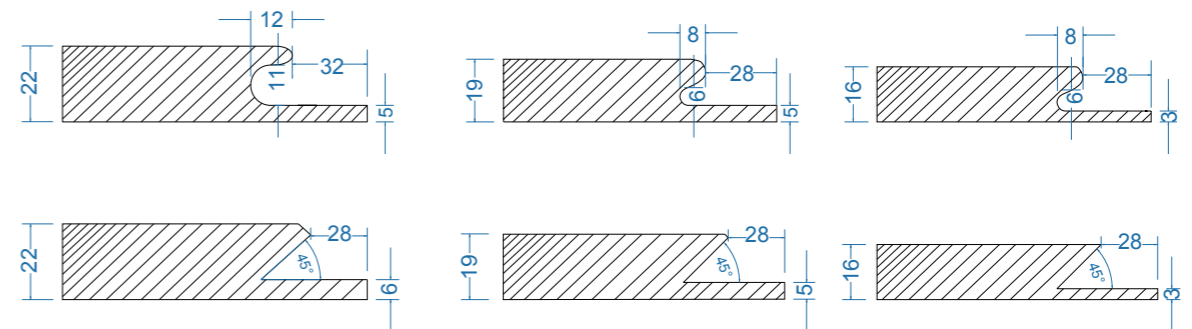



## ДЕКОРАТИВНЫЕ ЭЛЕМЕНТЫ



## КАРНИЗЫ



Возможная длина карнизов  
675/ 1350/ 2700 мм

Любой карниз  
изготавливается  
гнутый и вогнутый  
R-300

## НАКЛАДКИ НА КАРНИЗЫ

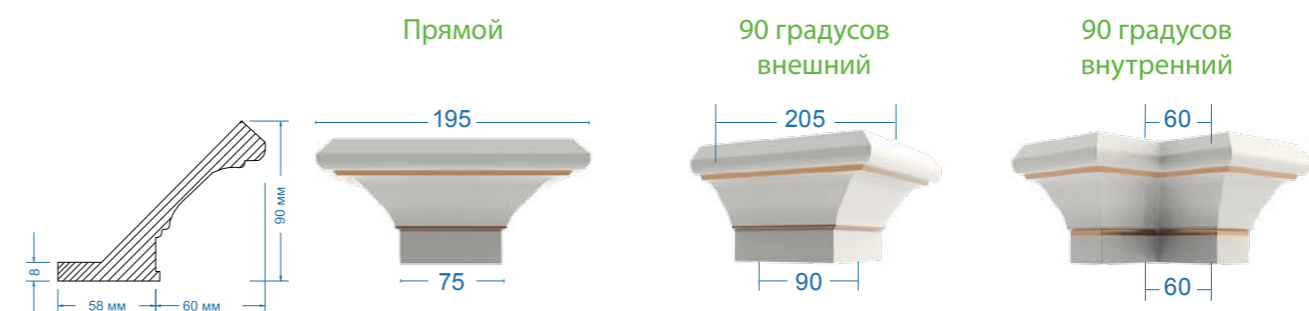



## РАСПОЛОЖЕНИЕ КАРНИЗА, ПОДКАРНИЗНОЙ ПЛАНКИ И НИЖНЕЙ ПЛАНКИ

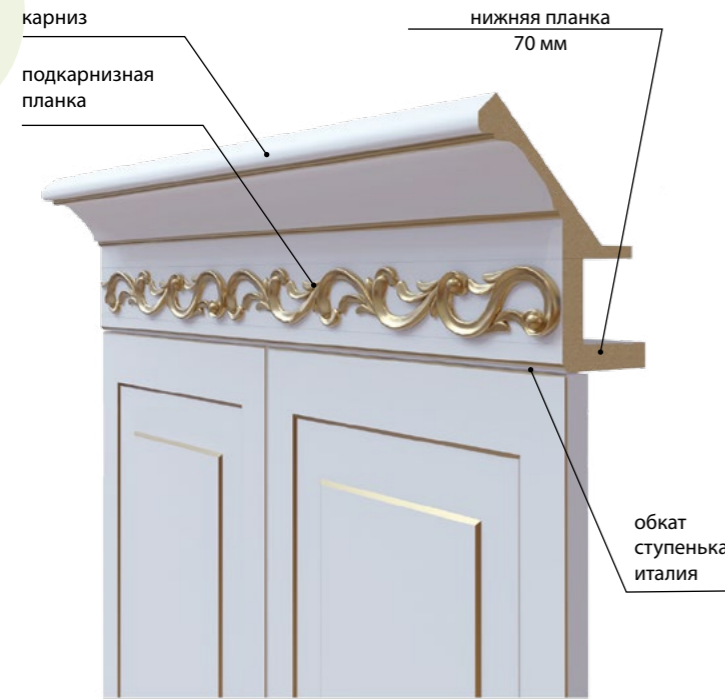

## ПЬЕДЕСТАЛ (ПОД КОЛОНУ 3D)

- высота зависит от высоты цоколя
- ширина зависит от ширины колонны

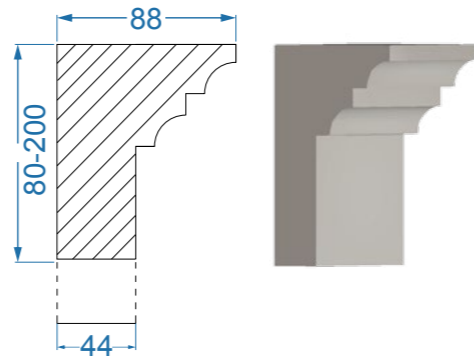

## ПОДКАРНИЗНЫЕ ПЛАНКИ

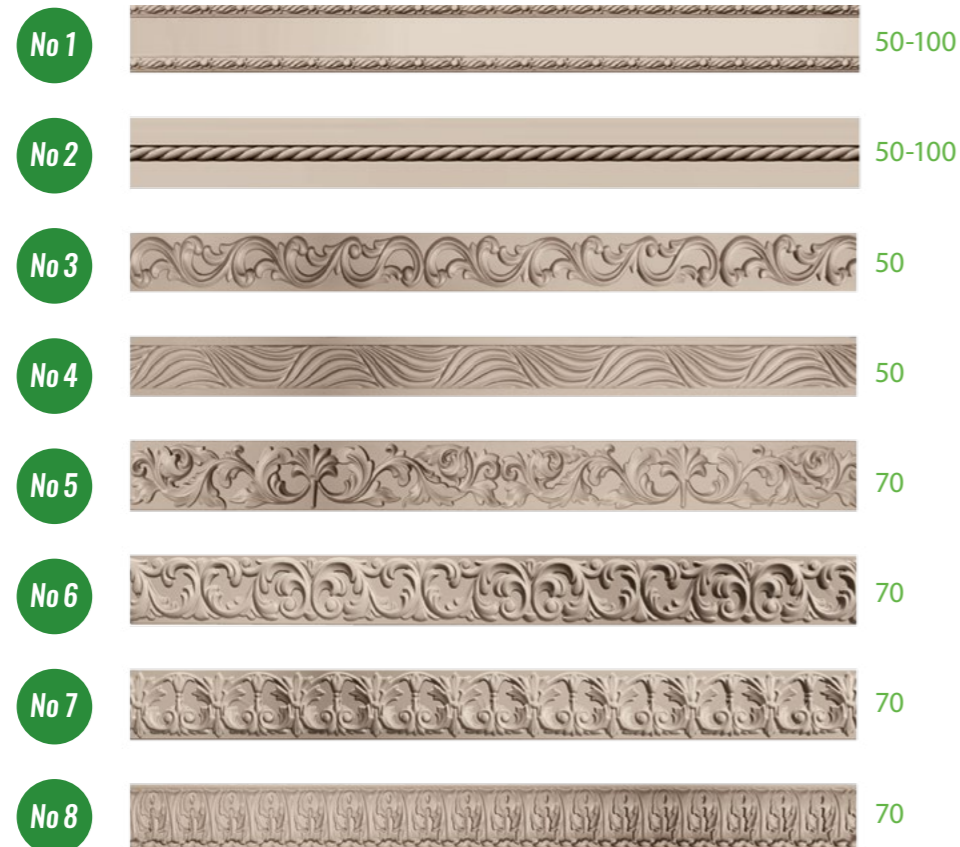

возможный размер балюстрады 800/1000 мм

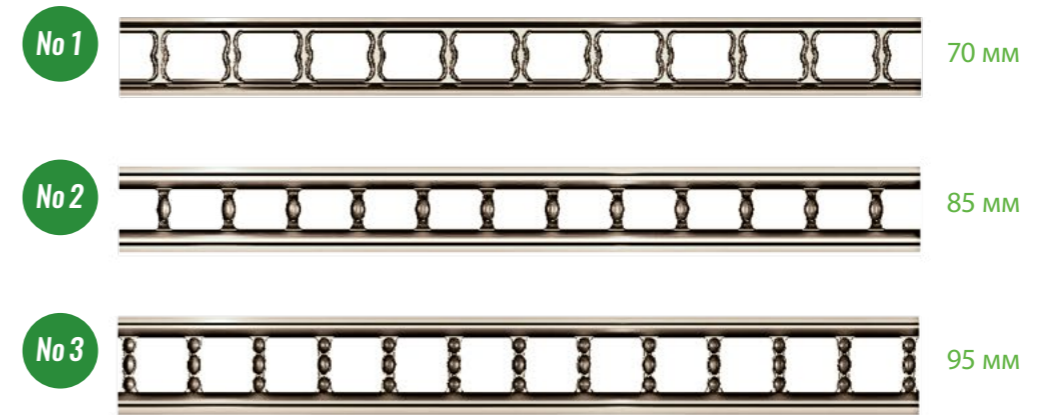

## КОЛОННЫ 2D ФРЕЗЕРОВАННЫЕ

ширина 50-200 мм, макс. высота 2700 мм, обкат по умолчанию ступ.ит.

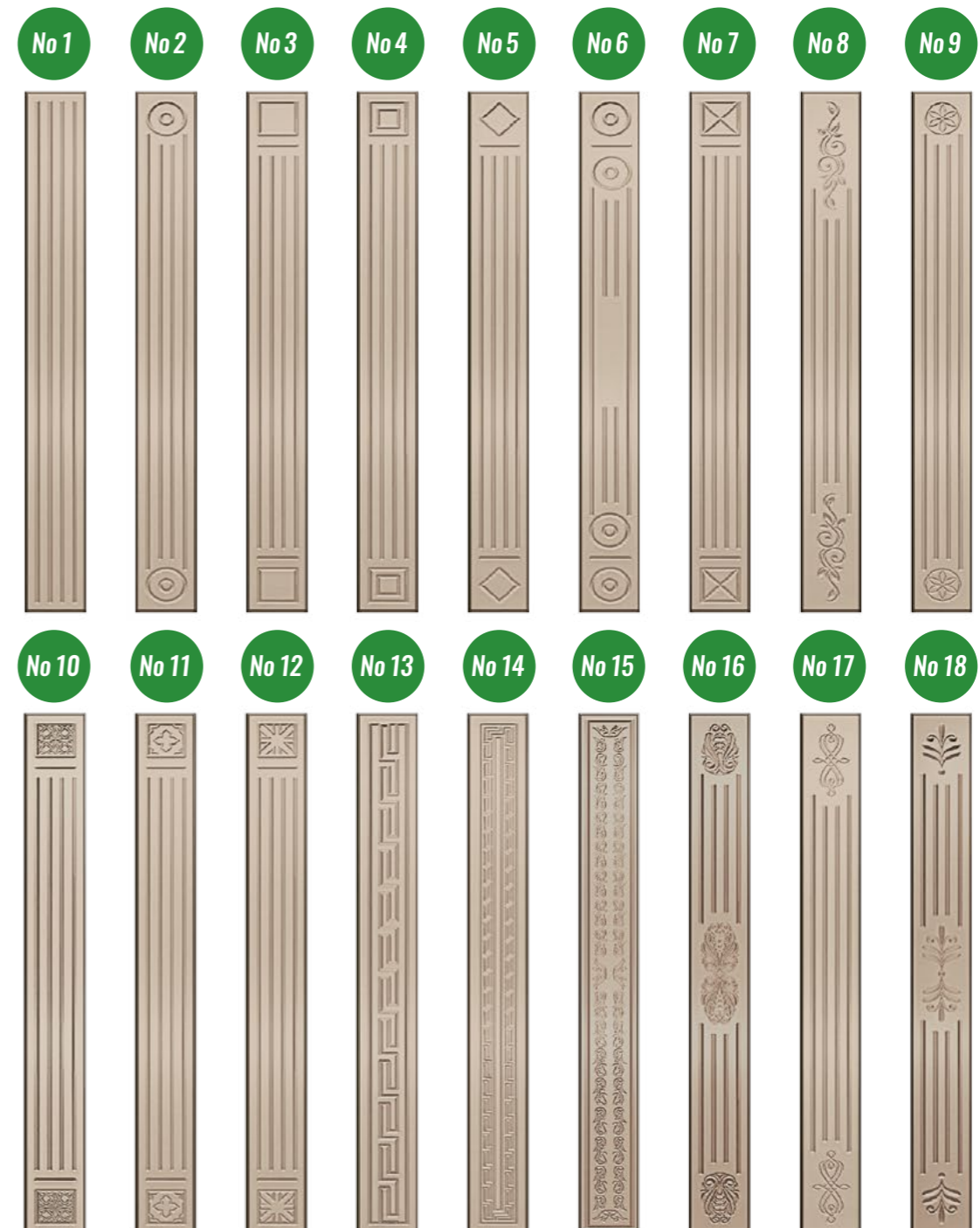



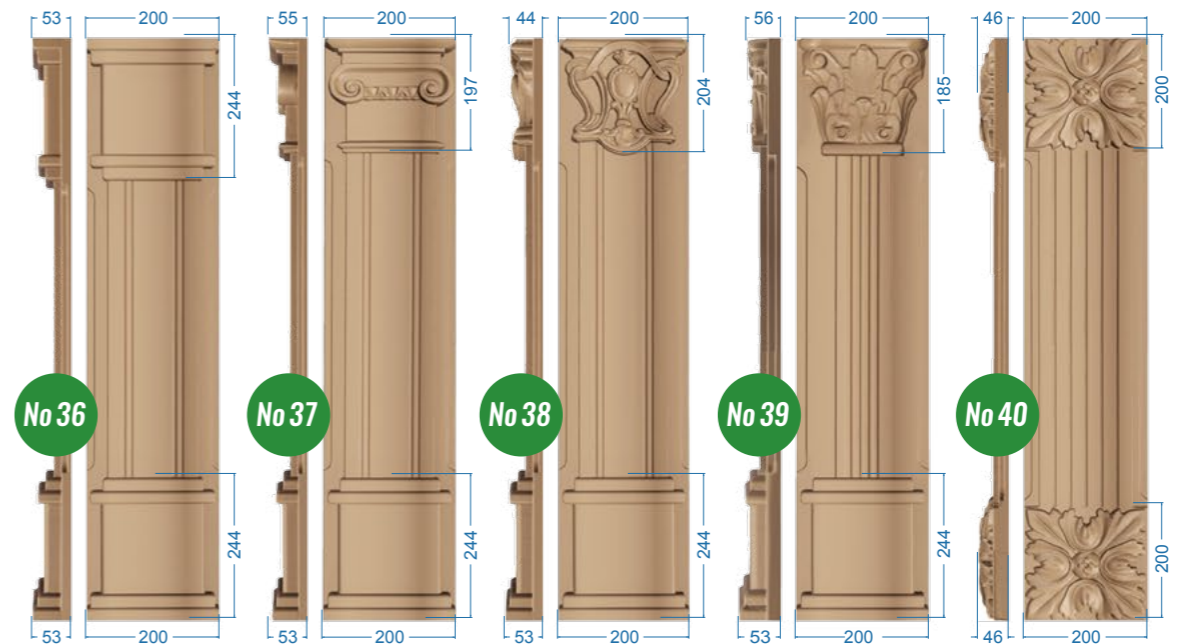
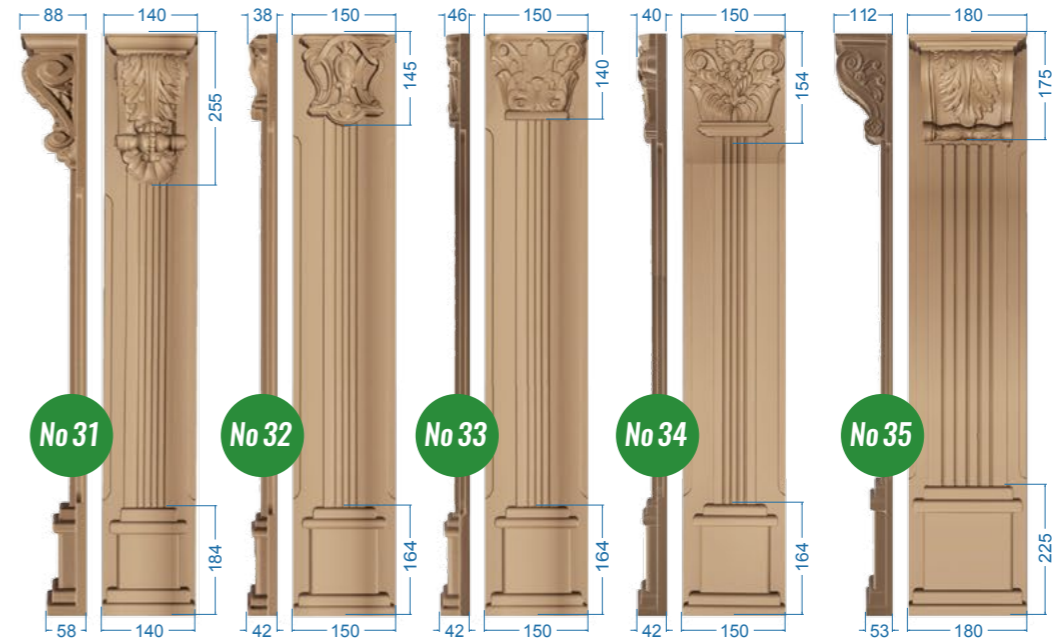
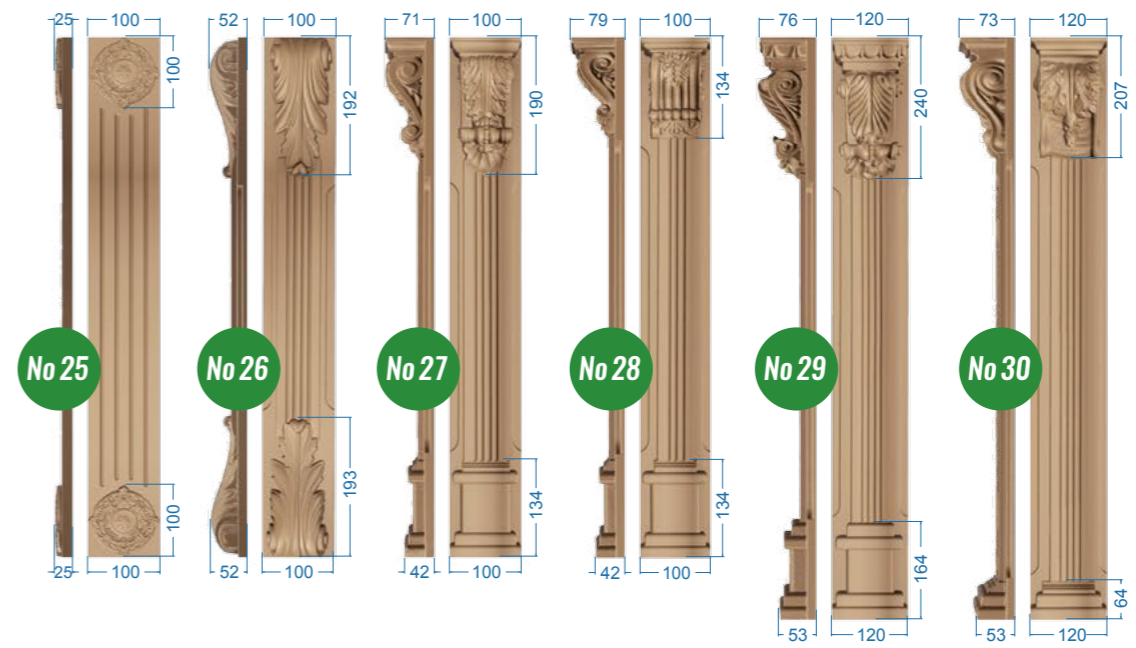
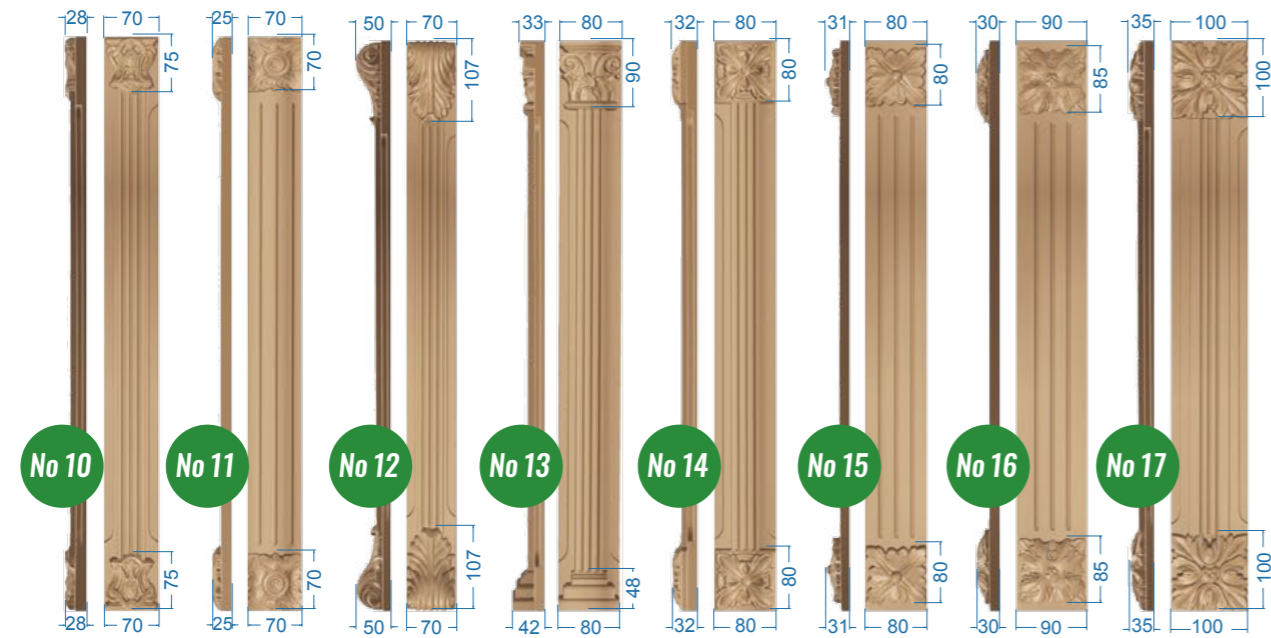
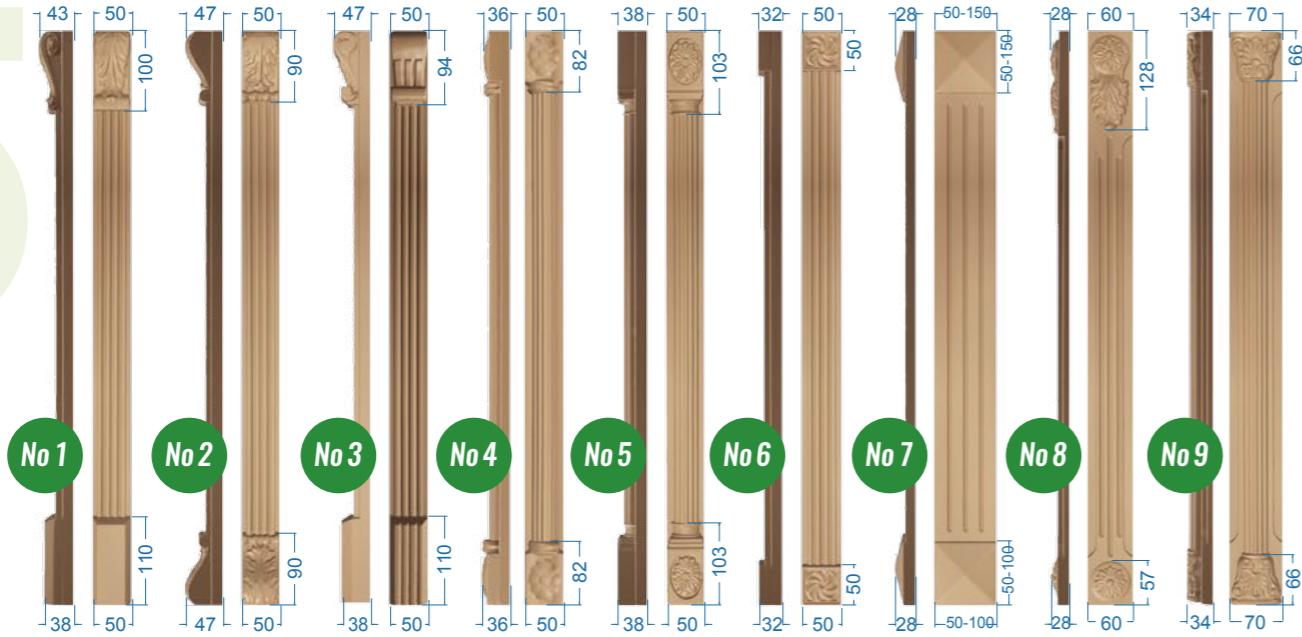

ДУГИ

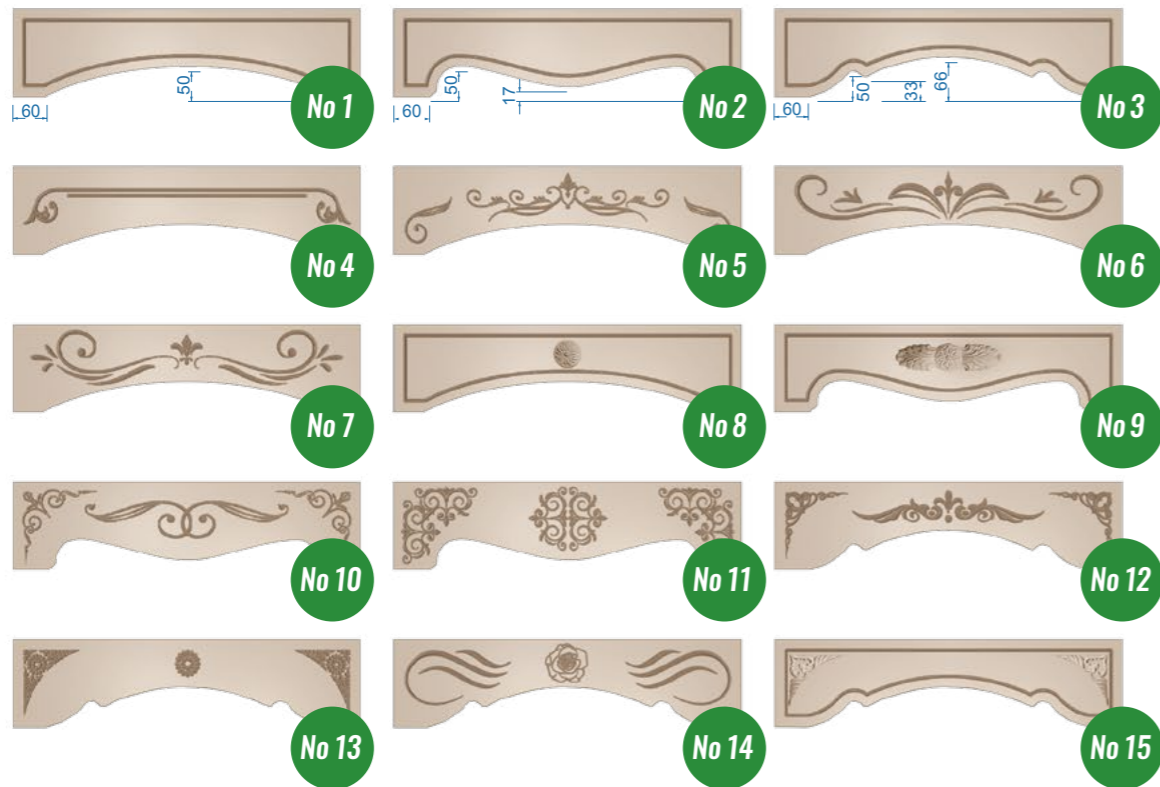

ДЕКОРЫ

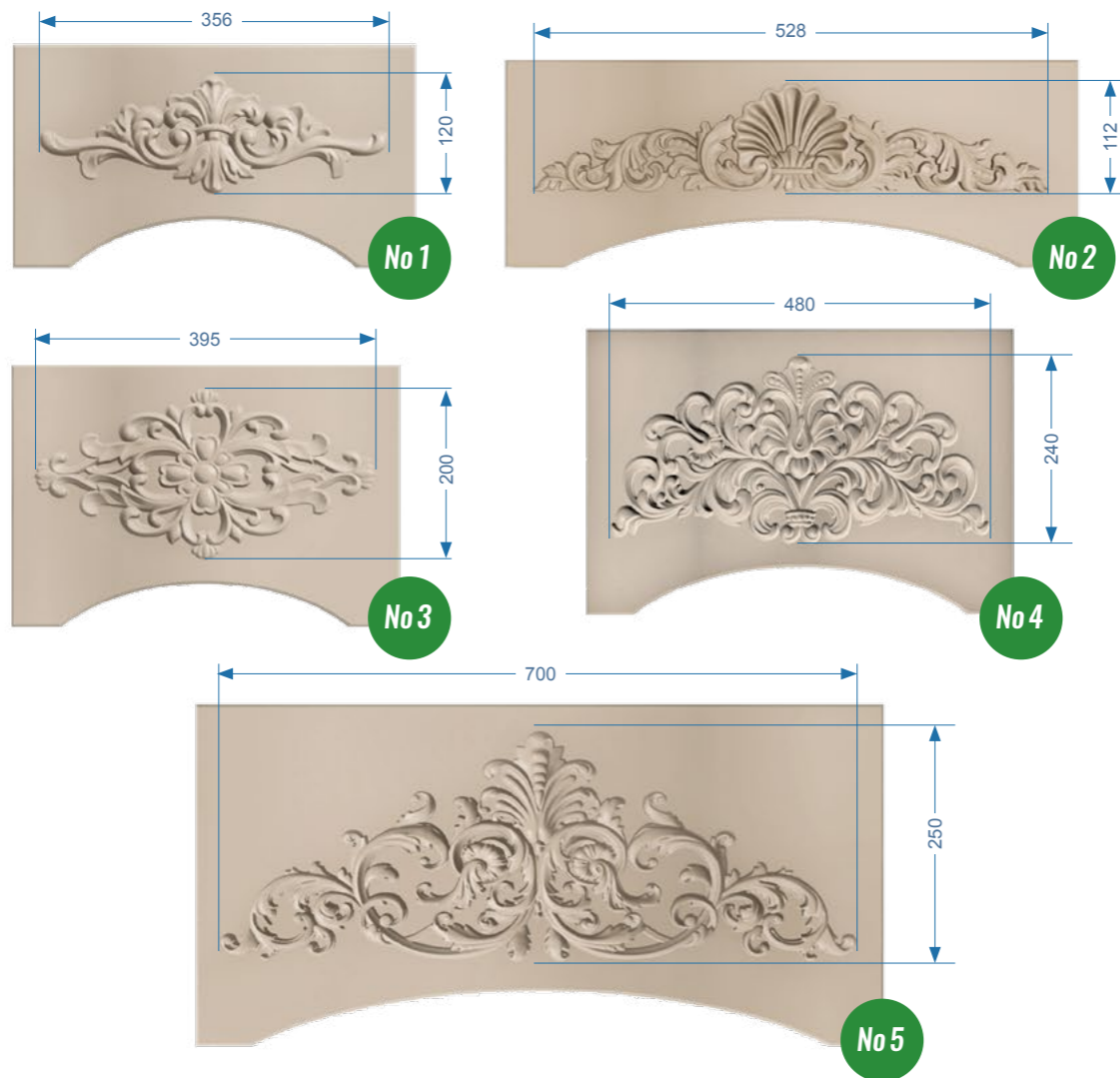

ФРИЗЫ (40-100 мм)

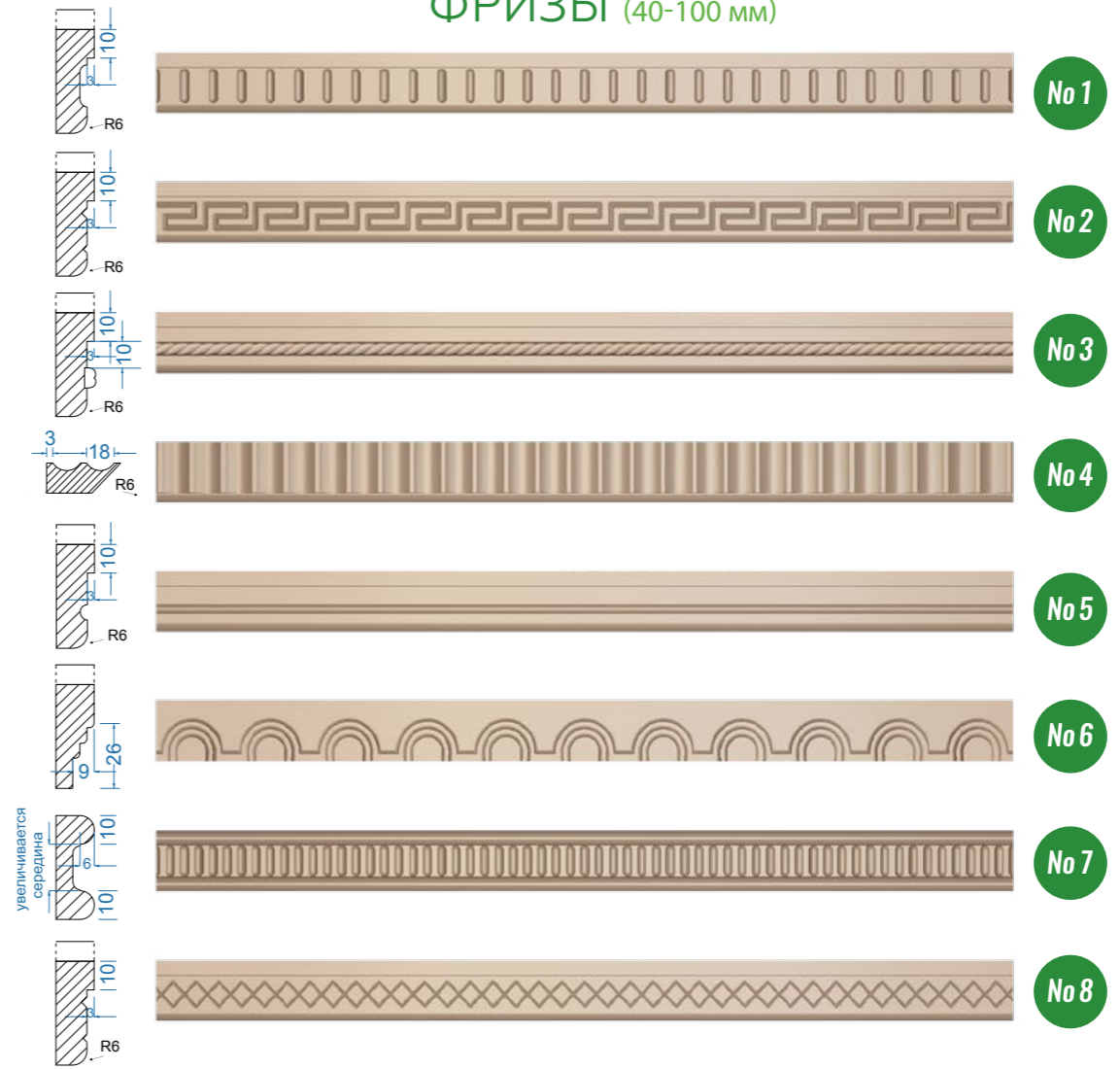

ЦОКОЛИ возможная ширина 80-200 мм

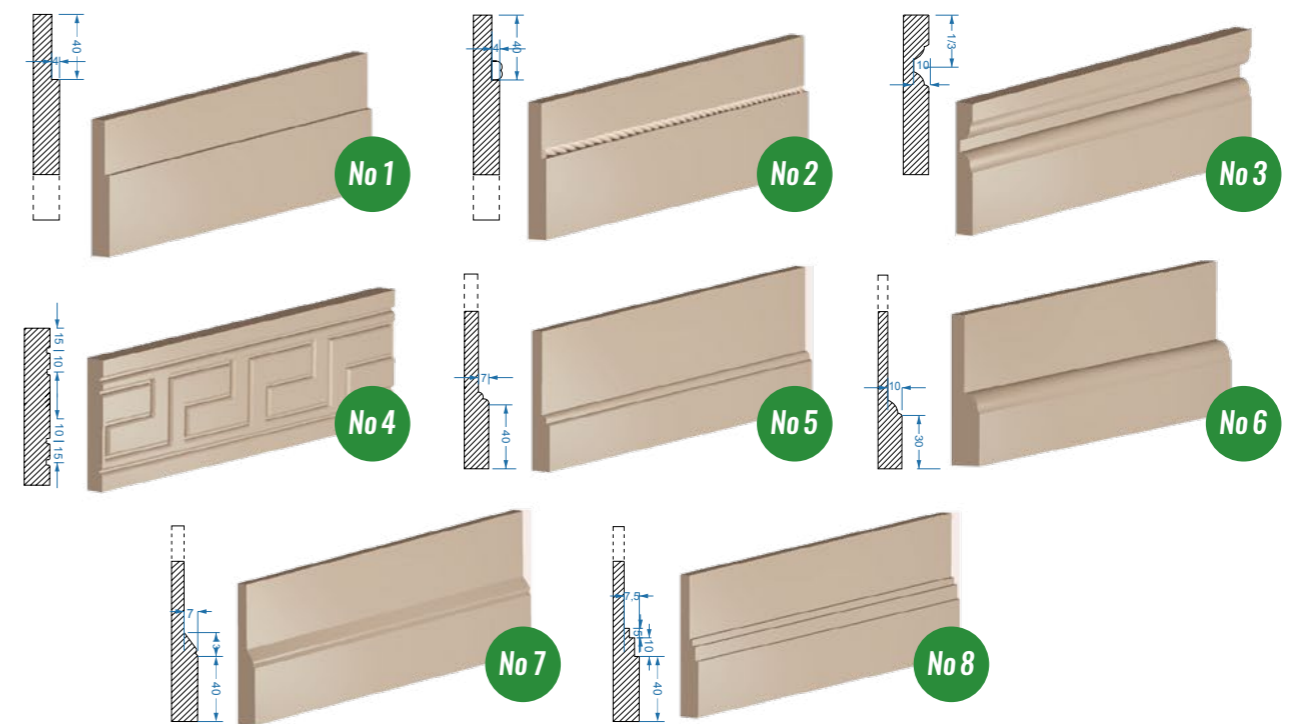



## СПОСОБЫ НАНЕСЕНИЯ ПАТИНЫ

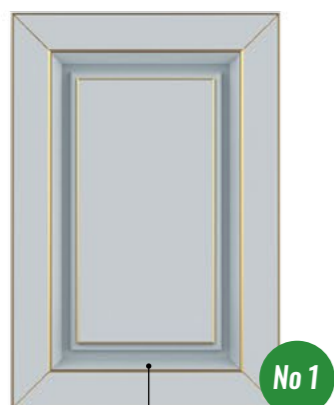

Выделение только тонких линий

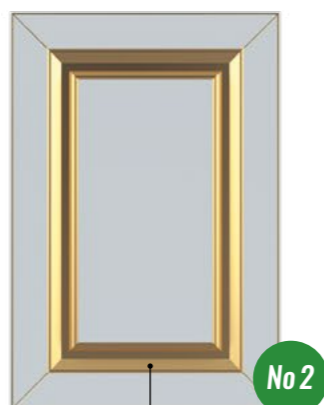

С тонкими линиями, дополнительно заполнено во фрезеровке

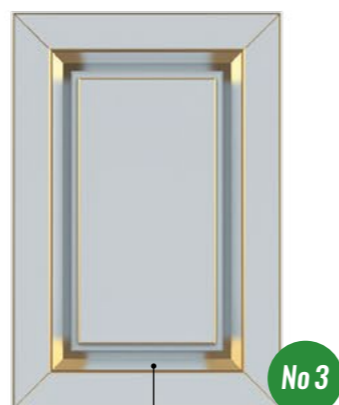

Выделение тонких линий с углами



Выделение тонких линий без рустов



В текстуре с выделением тонких линий



В текстуре с тонкими линиями, добела во фрезеровке



В текстуре с тонкими линиями, дополнительно заполнено во фрезеровке



Без текстуры, добела, с тонкими линиями



золото



шампань



бронза



медь



серебро



чёрная



коричневая



светло-коричневая



тёмно-коричневая

## ФАСАДЫ С ПОКРЫТИЕМ «ТИСНЕНИЕ»

Фасады МДФ, с отпечатанной текстурой дерева в эмали.  
Текстура может быть нанесена на простой гладкий фасад. На верхние плоскости фрезерованных фасадов, на рамки и вставки сборных фасадов.  
Максимальная толщина заготовки 50 мм, макс. ширина обработки 1300 мм.

ПЛОСКОСТИ С ТИСНЕНИЕМ

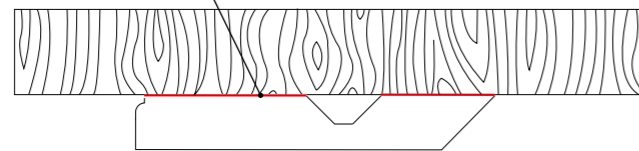

## ШТАПИКИ

штапик 1

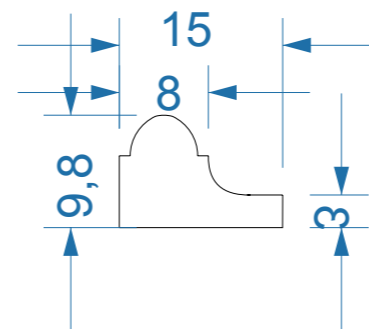

штапик 2

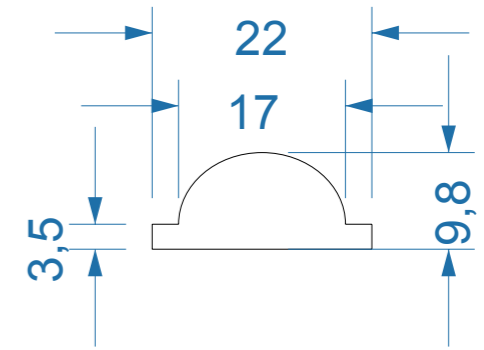

штапик 3

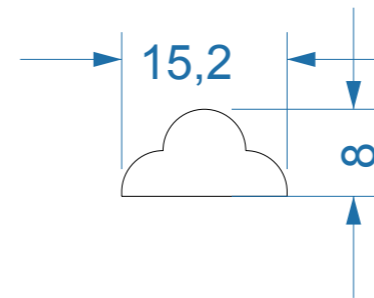

штапик 4

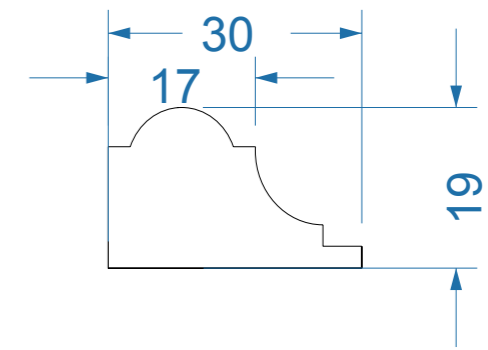

штапик 5

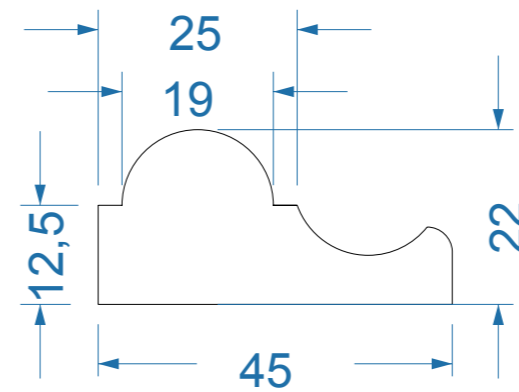

штапик 6

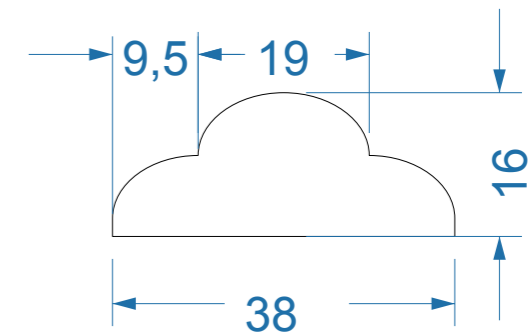



### R-300 ДУГОВОЙ

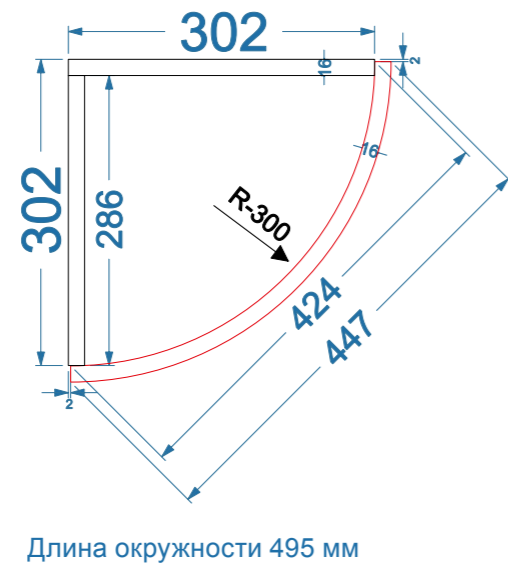
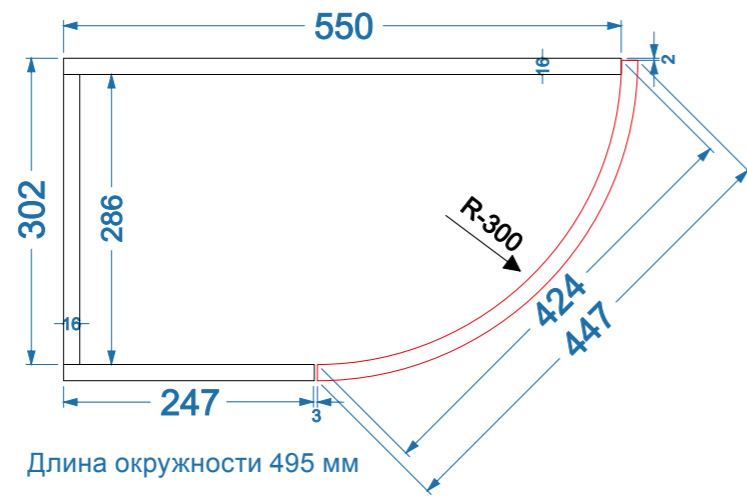

### R-300 ВОГНУТЫЙ

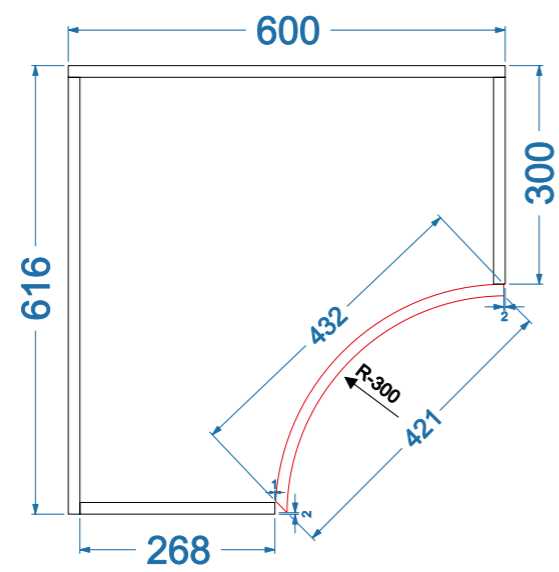

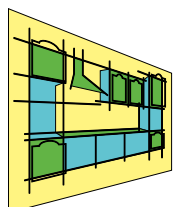

**ЮГФАСАД**  
МЕБЕЛЬНЫЕ ФАСАДЫ

- 📍 357430, Ставропольский край,  
г. Железноводск, п.Иноземцево,  
ул.Пионерская 73д.
- ☎ 8-905-444-45-55  
8-906-493-34-22
- ✉ ideal055@mail.ru

**График работы:**

пн.-пт.: с 9:00 до 18:00  
сб.: с 9:00 до 14:00  
вс.: ВЫХОДНОЙ